

3RD INTERNATIONAL CONFERENCE ON PARTICLE PHYSICS AND ASTROPHYSICS

OCTOBER 2 - 5, 2017

MOSCOW, RUSSIA

ICPPA-2017



DEADLINES

INVITATION REQUESTS — 21 AUG 2017

REGISTRATION — 21 AUG 2017

PROCEEDINGS — 10 NOV 2017

The Grand Palace in Tsaritsyno park, Moscow

Theory Vision of HEP' 17

Dmitry Kazakov
JINR (Dubna)



THE PRINCIPLES

- Three gauged symmetries $SU(3) \times SU(2) \times U(1)$
- Three families of quarks and leptons (3 \times 2, 3 \times 1, 1 \times 2, 1 \times 1)
- Brout-Englert-Higgs mechanism of spontaneous EW symmetry breaking \rightarrow Higgs boson
- CKM and PMNS mixing of flavours
- CP violation via phase factors
- Confinement of quarks and gluons inside hadrons
- Baryon and lepton number conservation
- CPT invariance \rightarrow existence of antimatter

The ST principles allow:

- Extra families of quarks and leptons
- Presence or absence of right-handed neutrino
- Majorana or Dirac nature of neutrino
- Extra Higgs bosons

THE LAGRANGIAN

$$\mathcal{L} = \mathcal{L}_{gauge} + \mathcal{L}_{Yukawa} + \mathcal{L}_{Higgs},$$

$$\mathcal{L}_{gauge} = -\frac{1}{4}G_{\mu\nu}^a G_{\mu\nu}^a - \frac{1}{4}W_{\mu\nu}^i W_{\mu\nu}^i - \frac{1}{4}B_{\mu\nu} B_{\mu\nu} + i\bar{L}_\alpha \gamma^\mu D_\mu L_\alpha + i\bar{Q}_\alpha \gamma^\mu D_\mu Q_\alpha + i\bar{E}_\alpha \gamma^\mu D_\mu E_\alpha + i\bar{U}_\alpha \gamma^\mu D_\mu U_\alpha + i\bar{D}_\alpha \gamma^\mu D_\mu D_\alpha + (D_\mu H)^\dagger (D_\mu H),$$

$$+i\bar{N}_\alpha \gamma^\mu \partial_\mu N_\alpha$$

possible right handed neutrino ?

$$\mathcal{L}_{Yukawa} = y_{\alpha\beta}^L \bar{L}_\alpha E_\beta H + y_{\alpha\beta}^D \bar{Q}_\alpha D_\beta H + y_{\alpha\beta}^U \bar{Q}_\alpha U_\beta \tilde{H} + h.c.,$$

$$+y_{\alpha\beta}^N \bar{L}_\alpha N_\beta \tilde{H}$$

$$\mathcal{L}_{Higgs} = -V = m^2 H^\dagger H - \frac{\lambda}{2} (H^\dagger H)^2$$

All these parameters are not predicted by the SM and determined experimentally

Three gauge couplings

Three or four Yukawa matrices

Two parameters

THE PROBLEMS

The running couplings possess the Landau ghost poles at high energies

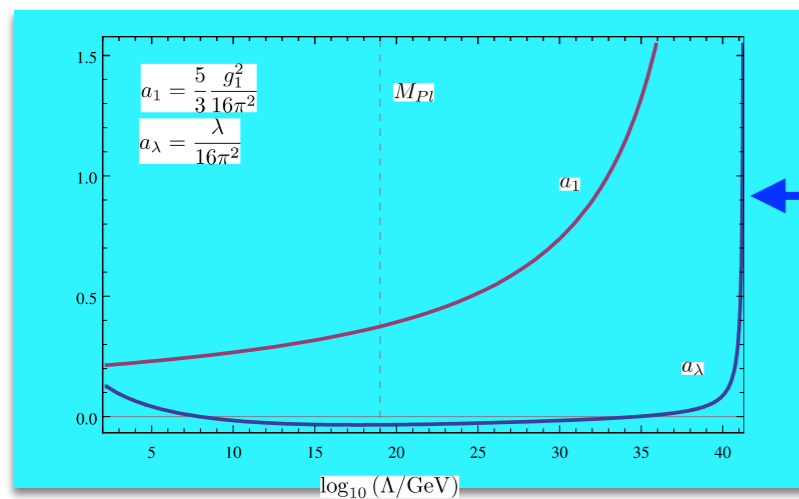

- The ghost pole exist for the U(1) coupling and for the Higgs coupling, but ... beyond the Planck scale

Quantum corrections can make the vacuum unstable



the situation crucially depends on the top and Higgs mass values and requires severe fine-tuning and accuracy

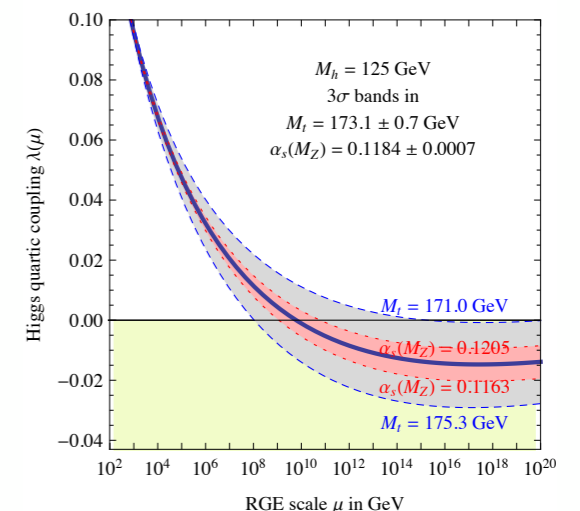

- The situation may change in GUTs due to new heavy fields @ the GUT scale

- requires modification of the ST at VERY high energies

THE PROBLEMS

👤 New physics at high scale may destroy the EW scale of the SM

- The Higgs sector is not protected by any symmetry
- This does not happen with the gauge bosons or fermions. Their masses are protected by gauge invariance and chiral nature of the EW sector
- Quantum corrections to the Higgs potential due to New physics

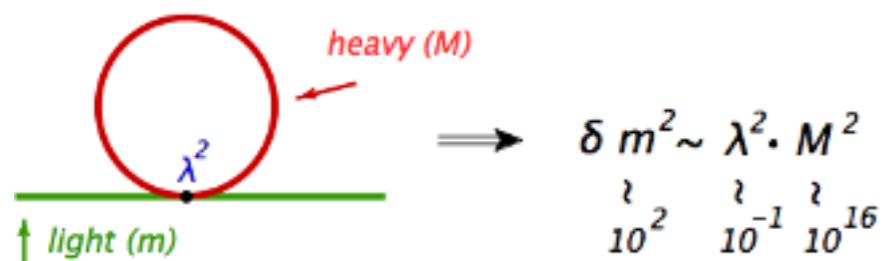

- creates the hierarchy problem
- requires modification of the SM

$$\frac{m_H}{m_{GUT}} \sim 10^{-14}$$

- This is not the problem of the SM itself (quadratic divergences are absorbed into the unobservable bare mass).
- This creates power law dependence of the low energy physics on unknown high energy physics that is not acceptable
 - The way out might be the new physics at higher scale

THE OPEN QUESTIONS

Why's?

- 👤 why the $SU(3) \times SU(2) \times U(1)$?
- 👤 why 3 generations ?
- 👤 why quark-lepton symmetry?
- 👤 why V-A weak interaction?
- 👤 why L-R asymmetry?
- 👤 why B & L conservation?
- 👤 etc

- 👤 Is it self consistent ?
- 👤 Does it describe all experimental data?
- 👤 Are there any indications for physics beyond the SM?
- 👤 Is there another scale except for EW and Planck?
- 👤 Is it compatible with Cosmology? Where is dark matter?

How's?

- 👤 how confinement actually works ?
- 👤 how the quark-hadron phase transition happens?
- 👤 how neutrinos get a mass?
- 👤 how CP violation occurs in the Universe?
- 👤 how to protect the SM from would be heavy scale physics?

IS THERE ANOTHER SCALE EXCEPT FOR EW AND PLANK?

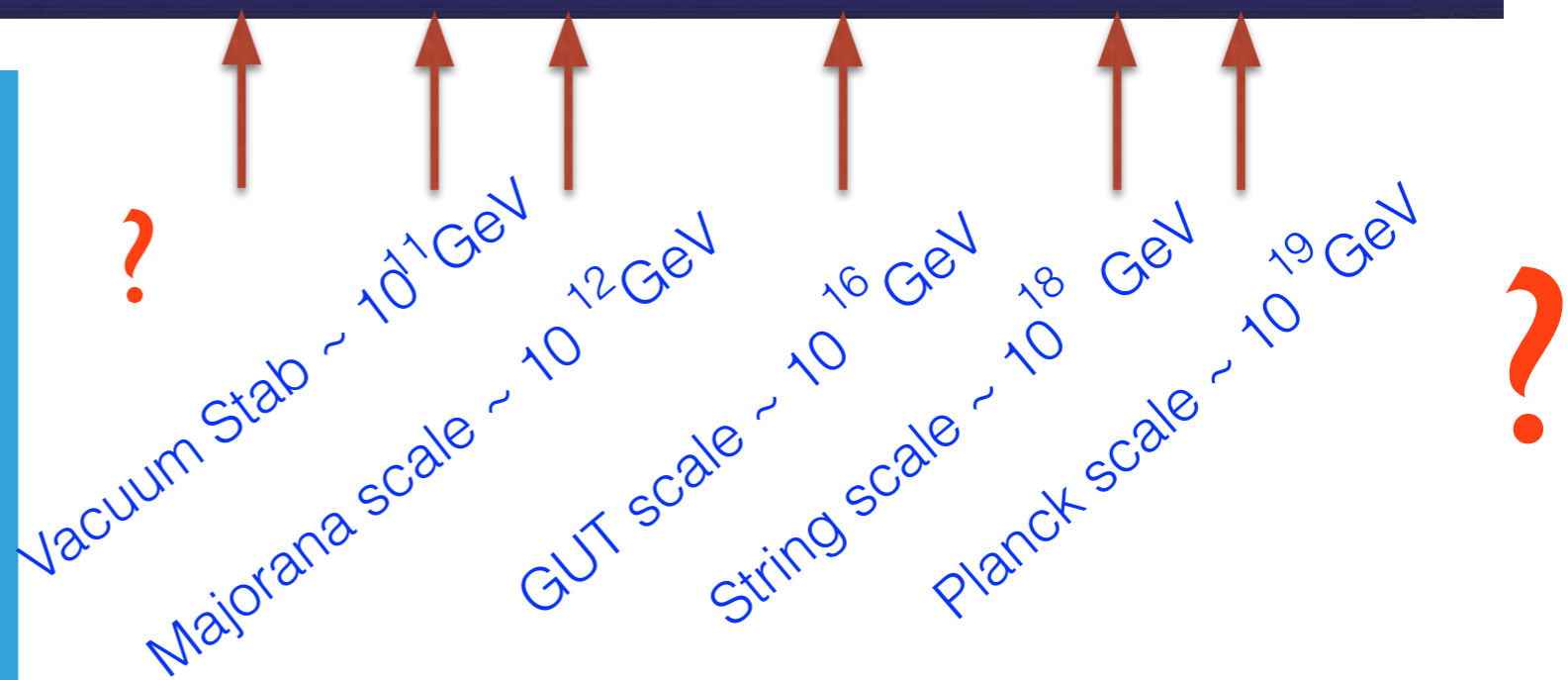
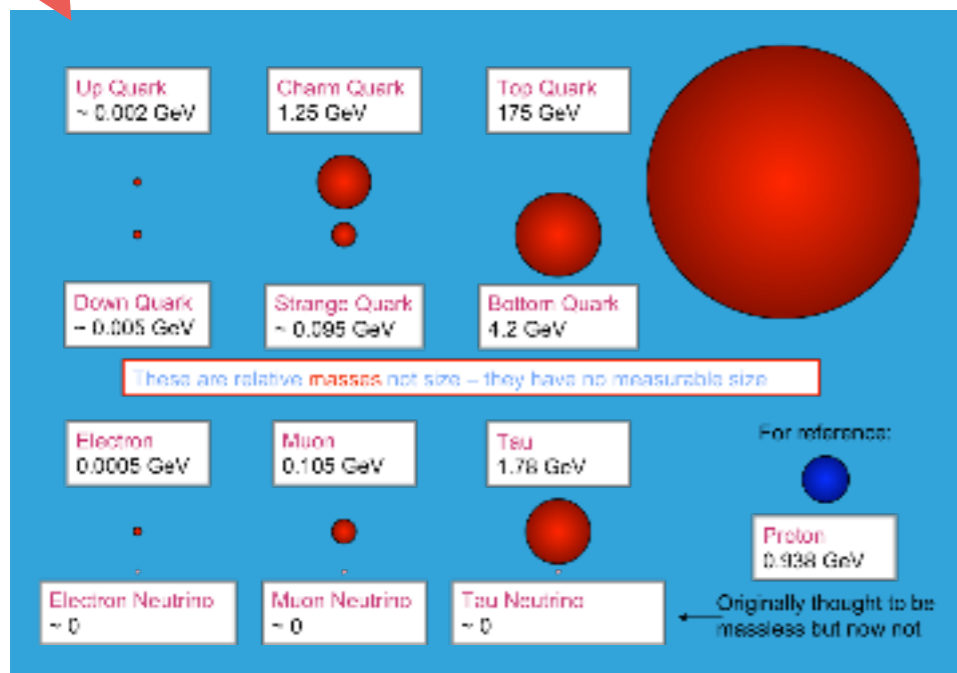

Today's feeling in HEP



We live in data driven era and need an
experimental hint to proceed

THE WAYS BEYOND

- 📌 Extension of symmetry group of the SM : SUSY, GUT, new U(1)'s
-> may solve the problem of Landau pole, the problem of stability, the hierarchy problem, may give the DM particle
- 📌 Additional particles: Extra generations, extra gauge bosons, extra Higgs bosons, extra neutrinos, etc
-> may solve the problem of stability, DM
- 📌 Extra dimensions: Compact or flat extra dim
-> Opens a whole new world of possibilities, may solve the problem of stability and the hierarchy problem, gives new insight into gravity
- 📌 New paradigm beyond local QFT: string theory, brane world, etc
-> main task is unification with gravity and construction of quantum gravity

The usual way

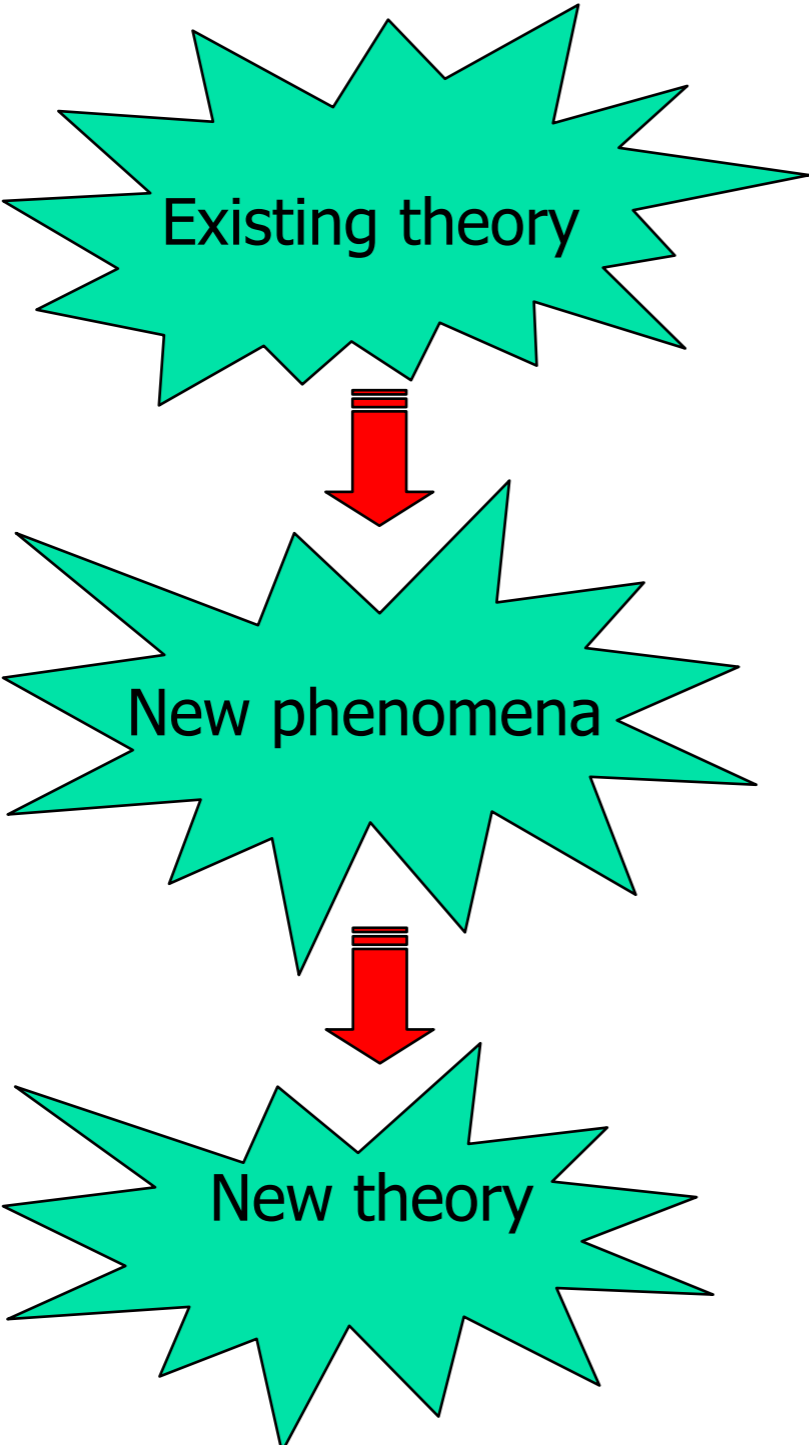

Modern HEP

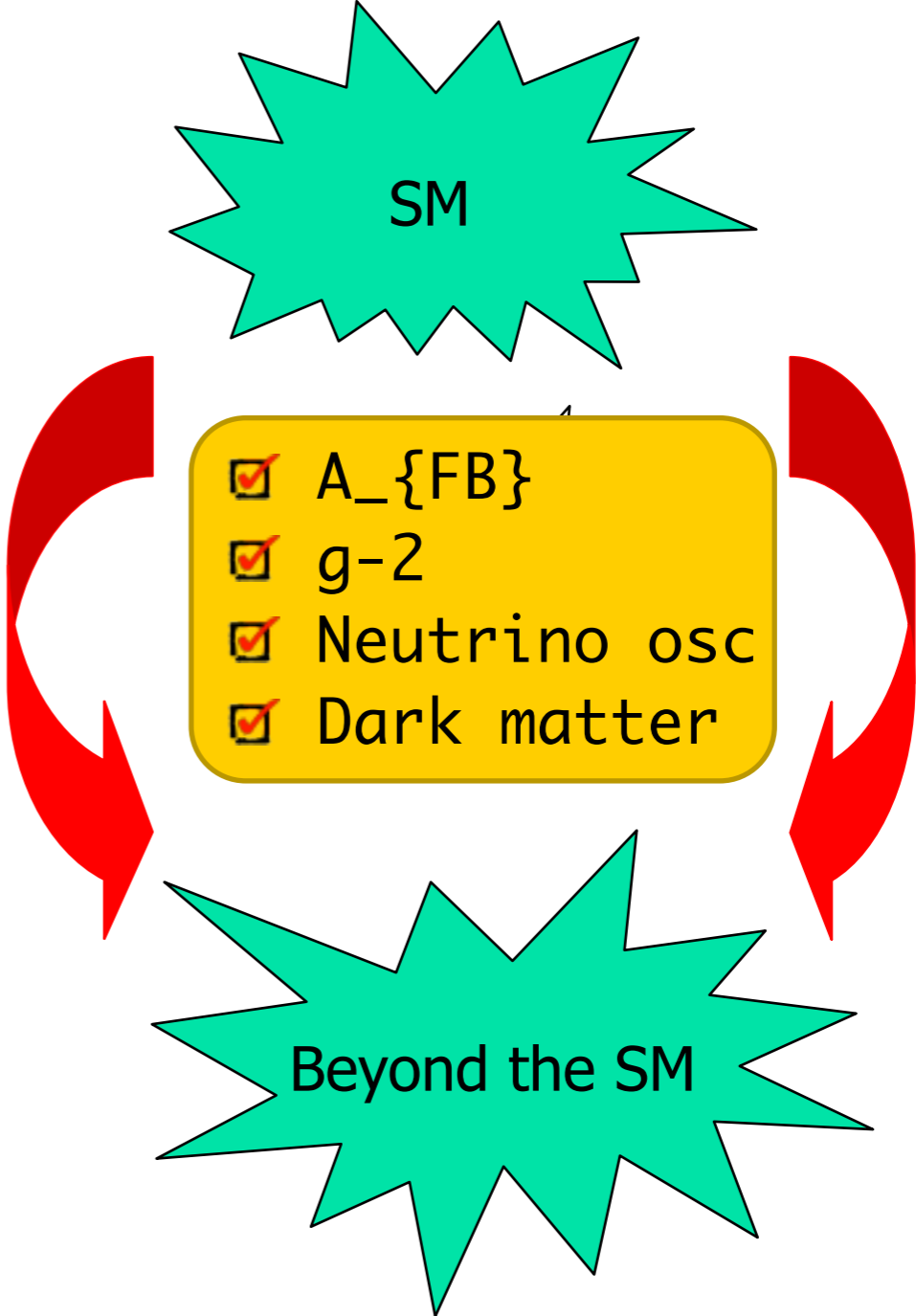

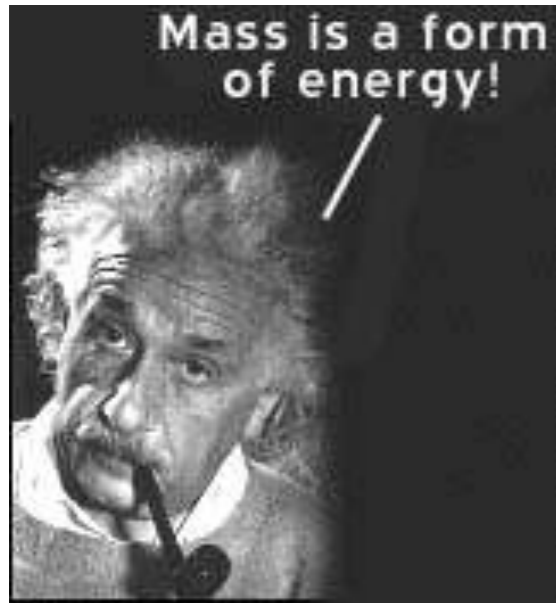

Unification Theories

Electricity and magnetism are different manifestations of a unified "electromagnetic" force. Electromagnetism, gravity, and the nuclear forces may be parts of a single unified force or interaction. Grand Unification and Superstring theories attempt to describe this unified force and make predictions which can be tested with the Tevatron.

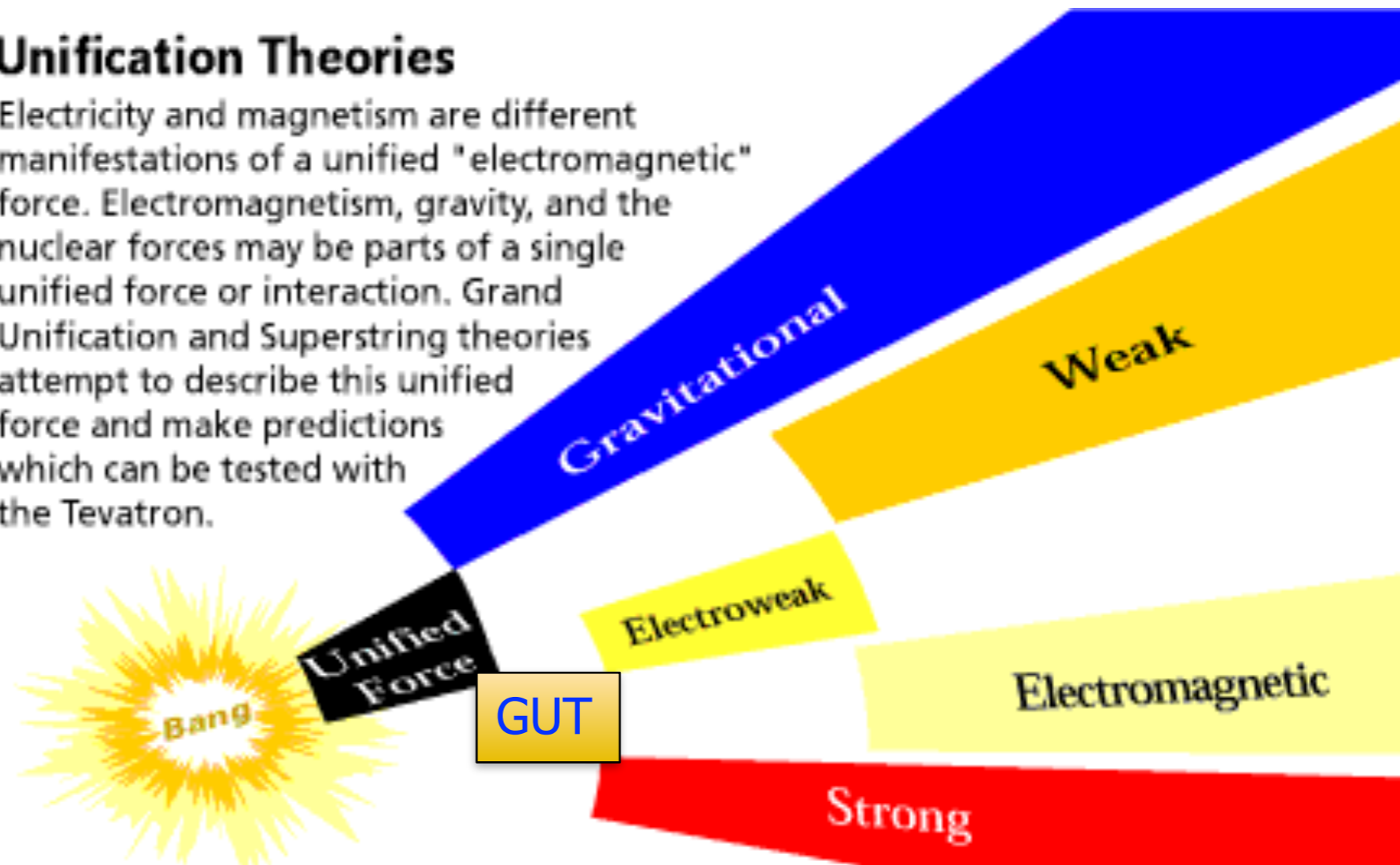

10^{-34} cm



D=10

- Unification of strong, weak and electromagnetic interactions within Grand Unified Theories is a new step in unification of all forces of Nature
- Creation of a unified theory of everything based on string paradigm seems to be possible

NEW SYMMETRIES

SUPERSYMMETRY

Supersymmetry is an extension of the Poincare symmetry of the SM

Poincare Algebra

$$\begin{aligned}
 [P_\mu, P_\nu] &= 0, \\
 [P_\mu, M_{\rho\sigma}] &= i(g_{\mu\rho}P_\sigma - g_{\mu\sigma}P_\rho), \\
 [M_{\mu\nu}, M_{\rho\sigma}] &= i(g_{\nu\rho}M_{\mu\sigma} - g_{\nu\sigma}M_{\mu\rho} - g_{\mu\rho}M_{\nu\sigma} + g_{\mu\sigma}M_{\nu\rho})
 \end{aligned}$$

Super Poincare Algebra

 Q_i, \bar{Q}_i

$$\begin{aligned}
 [Q_\alpha^i, P_\mu] &= [\bar{Q}_{\dot{\alpha}}^i, P_\mu] = 0, \\
 [Q_\alpha^i, M_{\mu\nu}] &= \frac{1}{2}(\sigma_{\mu\nu})_\alpha^\beta Q_\beta^i, & [\bar{Q}_{\dot{\alpha}}^i, M_{\mu\nu}] &= -\frac{1}{2}\bar{Q}_{\dot{\beta}}^i(\bar{\sigma}_{\mu\nu})^{\dot{\beta}}_{\dot{\alpha}}, \\
 \{Q_\alpha^i, \bar{Q}_{\dot{\beta}}^j\} &= 2\delta^{ij}(\sigma^\mu)_{\alpha\dot{\beta}} P_\mu, \\
 \{Q_\alpha^i, Q_\beta^j\} &= 2\epsilon_{\alpha\beta} Z^{ij}, & Z^{ij} &= Z_{ij}^+, \\
 \{\bar{Q}_{\dot{\alpha}}^i, \bar{Q}_{\dot{\beta}}^j\} &= -2\epsilon_{\dot{\alpha}\dot{\beta}} Z^{ij}, & [Z_{ij}, \text{anything}] &= 0, \\
 \alpha, \dot{\alpha} &= 1, 2 & i, j &= 1, 2, \dots, N.
 \end{aligned}$$

NEW SYMMETRIES

SUPERSYMMETRY

Supersymmetry is a dream of a unified theory of all particles and interactions

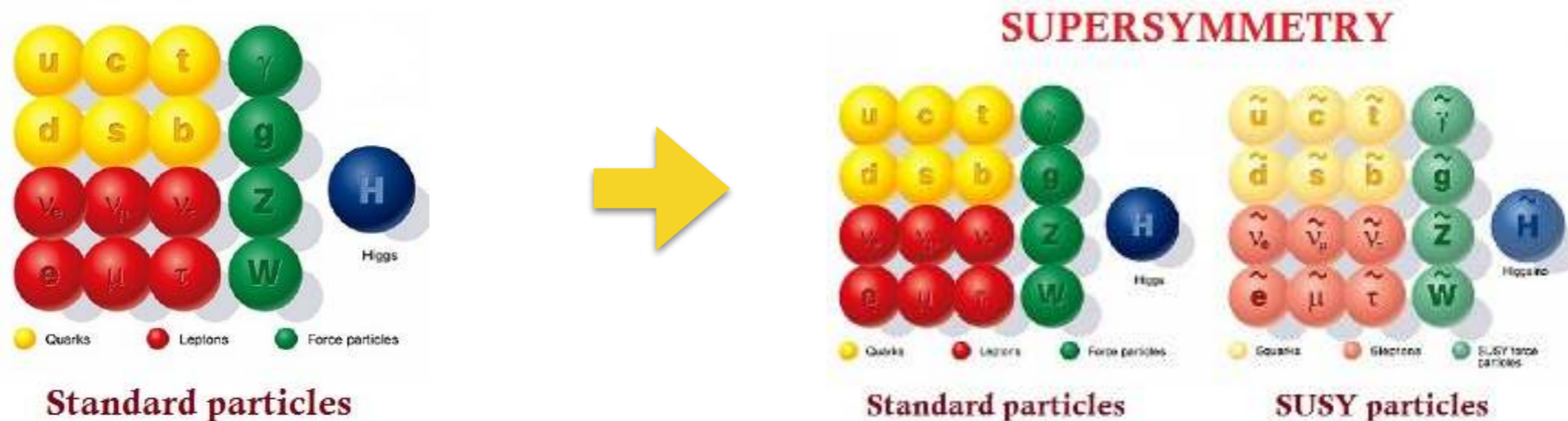

Supersymmetry remains, to this date, a well-motivated, much anticipated extension to the Standard Model of particle physics

- ◆ Advent of the LHC: huge new ground within reach
- ◆ A search is defined by its signature and by its background estimation method.
- ◆ If SUSY is the answer to the “naturalness” problem, then there must exist light colored particles
- ◆ This is a crucial moment: either we find SUSY at the LHC eventually or we have to solve the hierarchy problem some other way! (which way?)

Bosons and Fermions come in pairs

(φ, ψ)

(λ, A_μ)

(\tilde{g}, g)

Spin 0

Spin 1/2

Spin 1/2

Spin 1

Spin 3/2

Spin 2

scalar

chiral
fermion

majorana
fermion

vector

gravitino

graviton

$$R = (-)^{3(B-L)+2S}$$

The Usual Particle : $R = + 1$
 SUSY Particle : $R = - 1$

B - Baryon Number
 L - Lepton Number
 S - Spin

The consequences:

- The superpartners are created in pairs
- The lightest superparticle is stable



- The lightest superparticle (LSP) should be neutral - the best candidate is neutralino (photino or higgsino) $\tilde{\chi}_0$
- It can survive from the Big Bang and form the Dark matter in the Universe

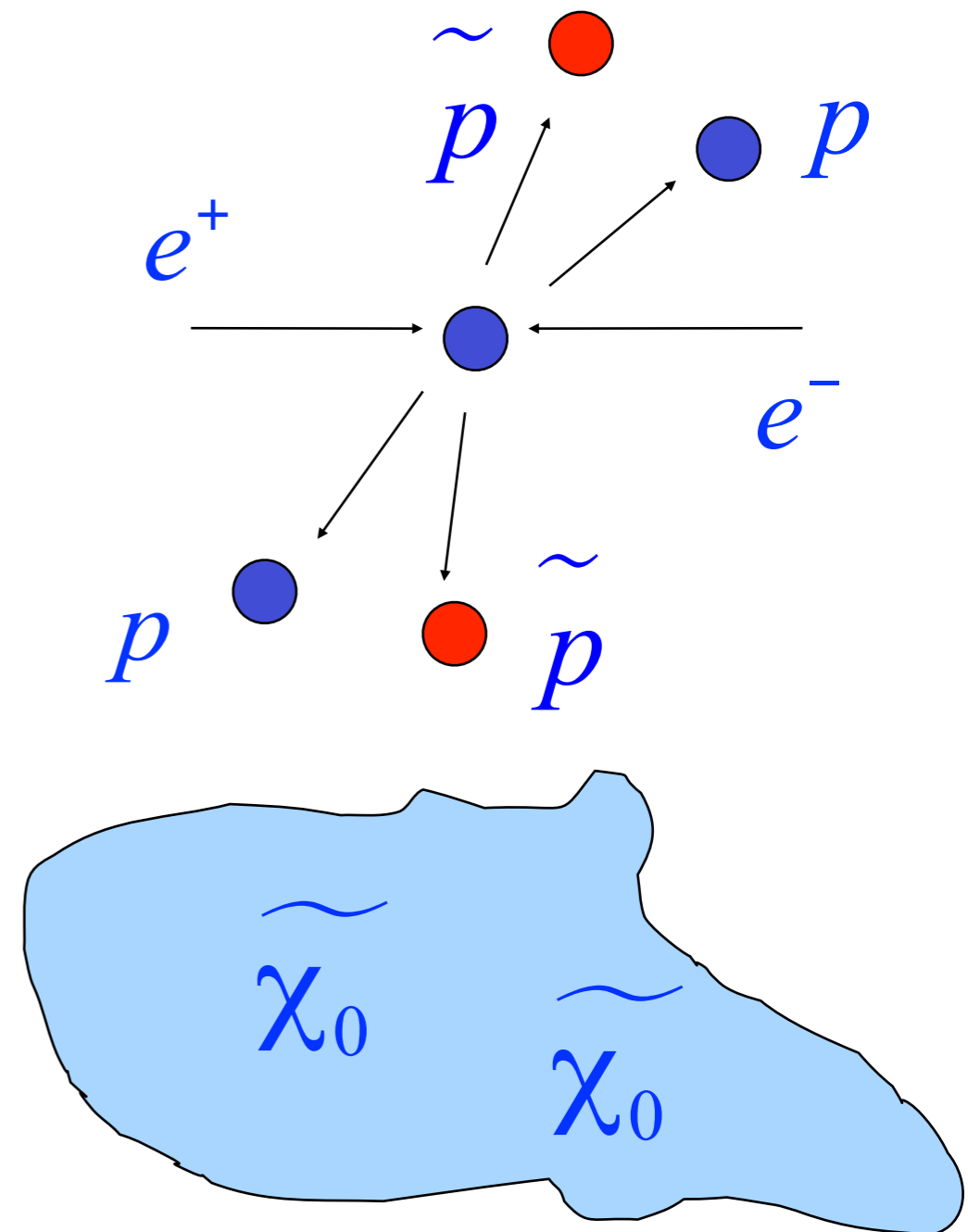

SUSY Models and Signatures

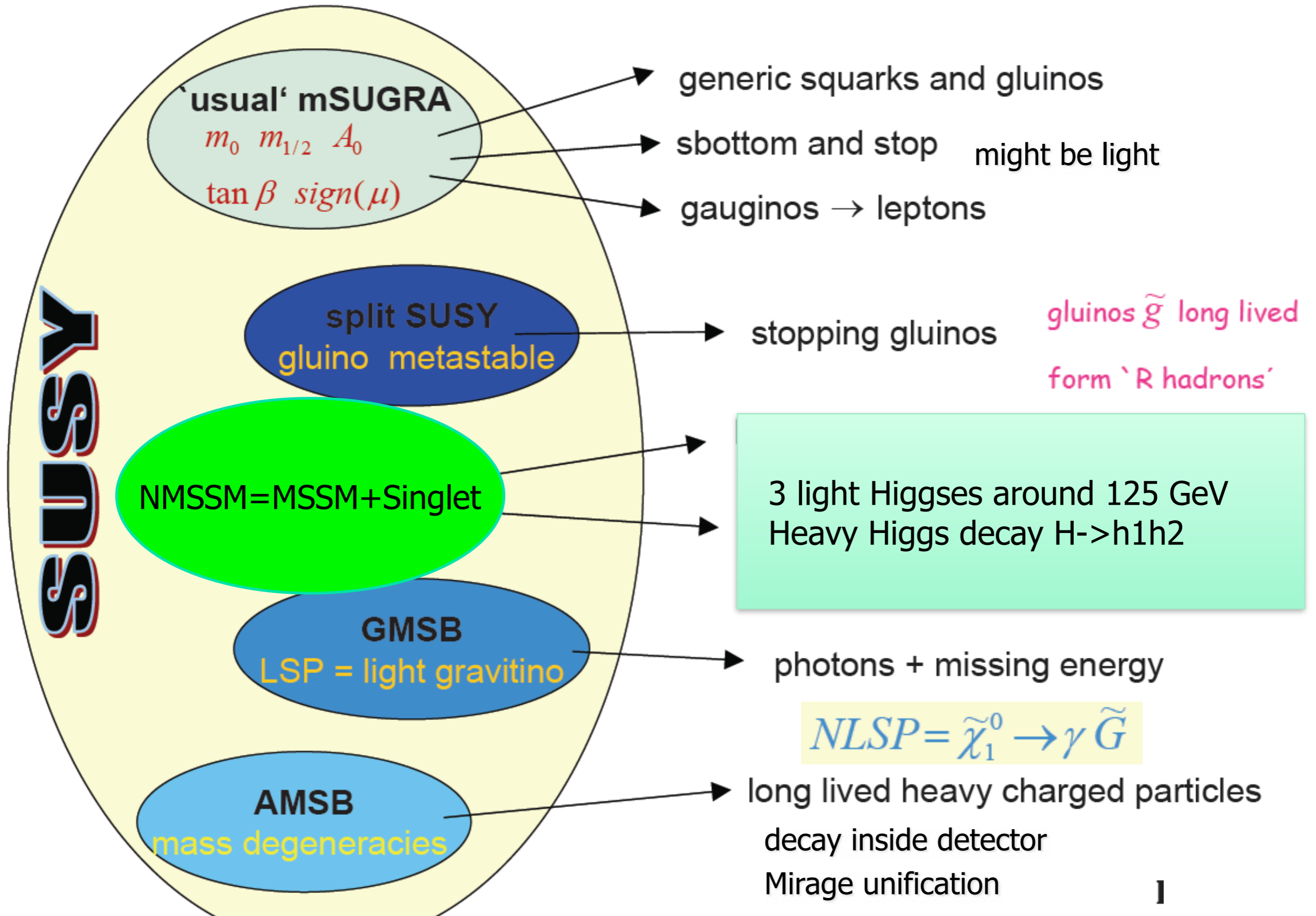

WHAT IS THE LHC REACH?

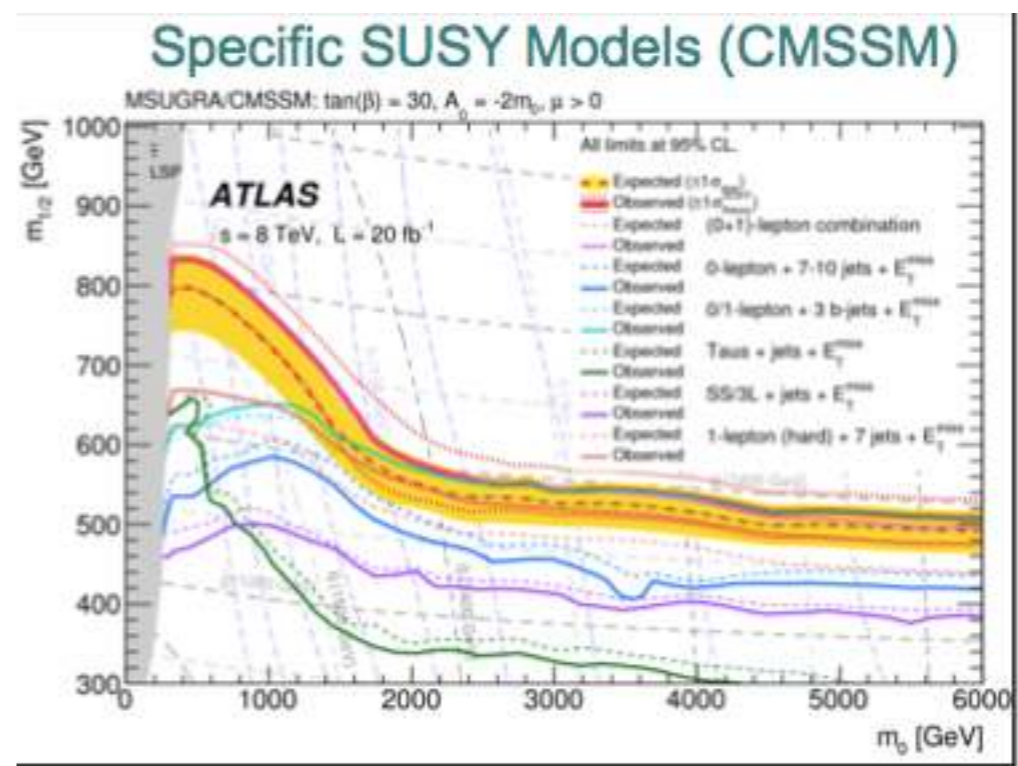
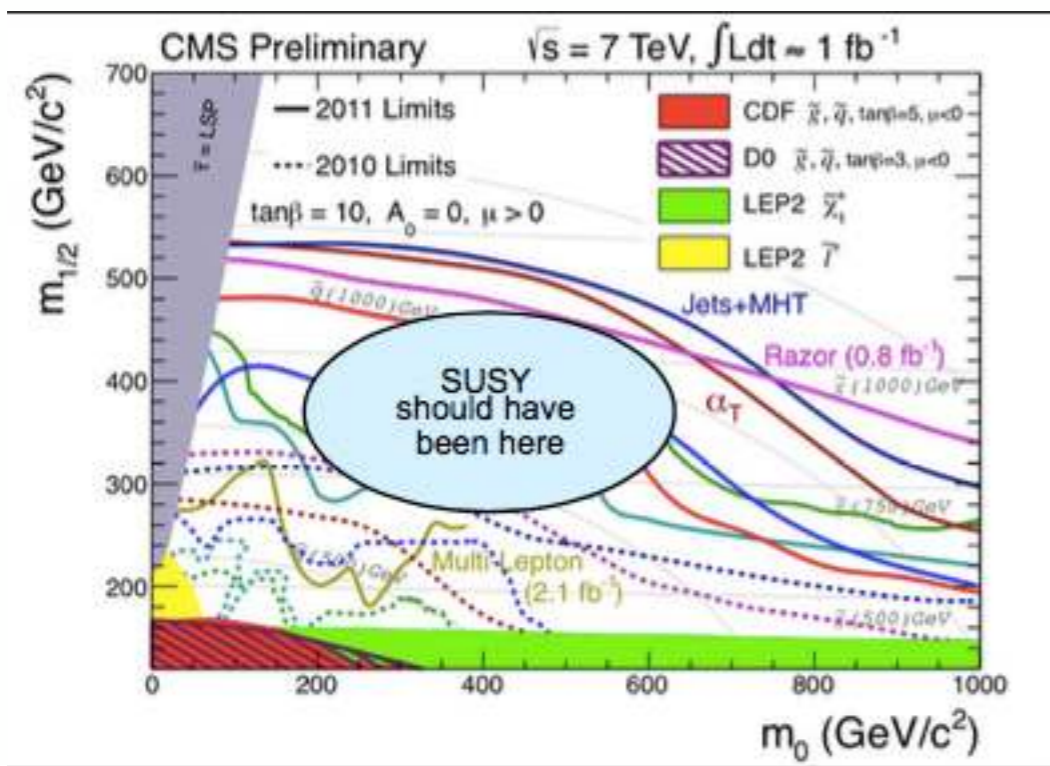

Universal parameters

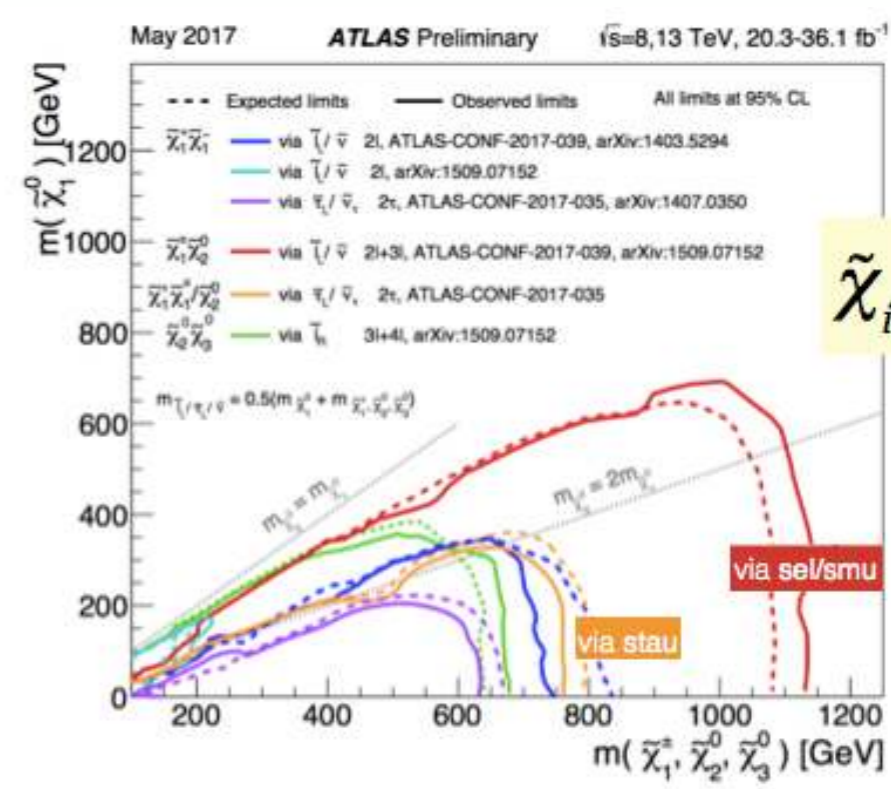
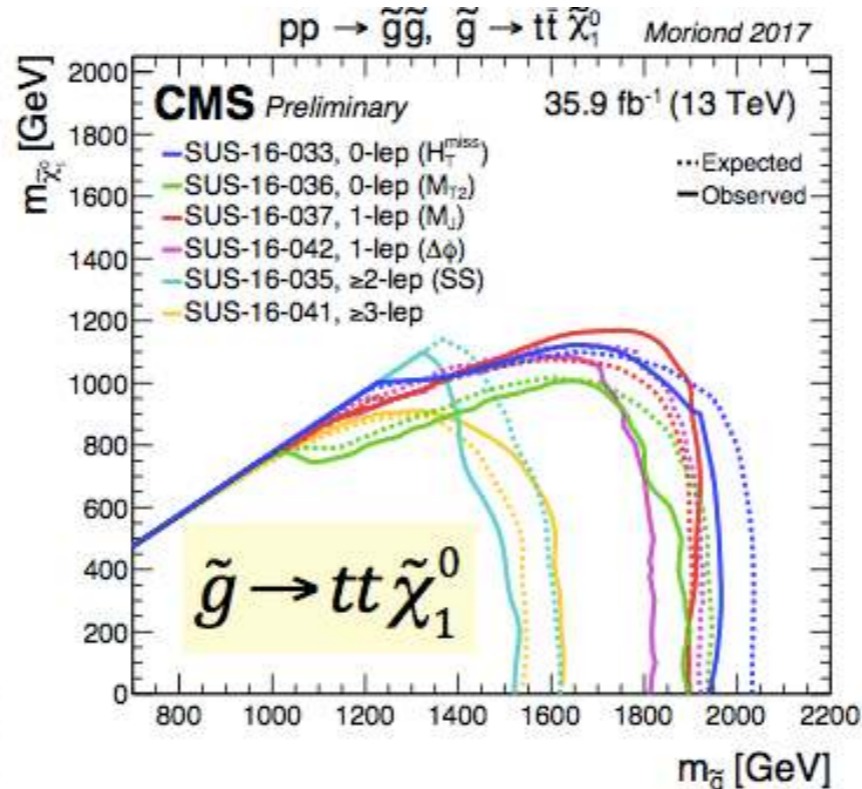
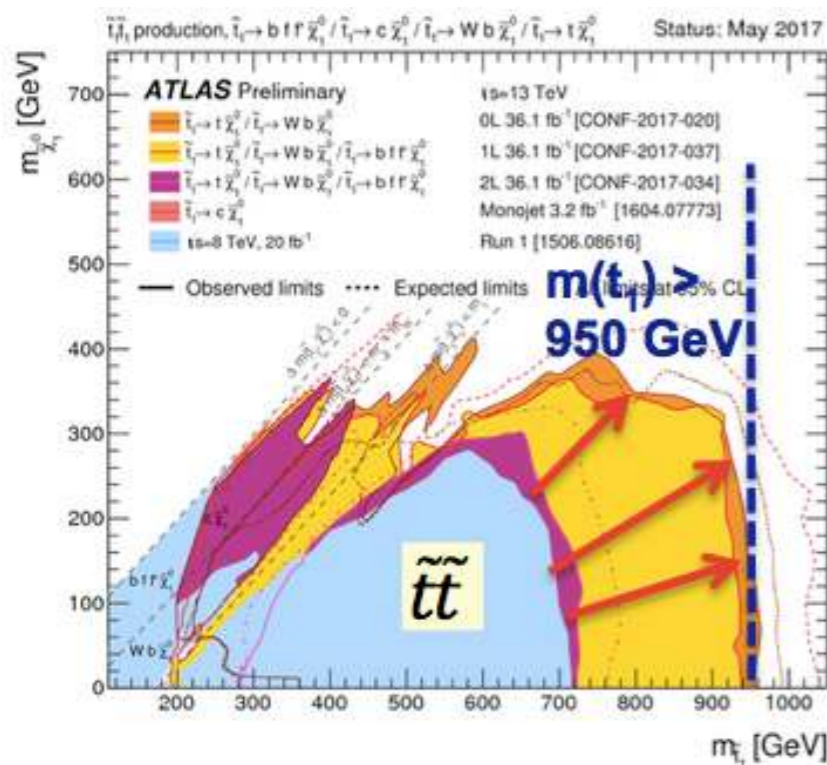

Masses of superpartners

NEW SYMMETRIES



GRAND UNIFICATION

Grand Unification is an extension of the Gauge symmetry of the SM

	Low energy		\Rightarrow	High energy
$SU_c(3) \otimes$	$SU_L(2) \otimes$	$U_Y(1)$	\Rightarrow	G_{GUT} (or G^n + discrete symmetry)
gluons	W, Z	photon	\Rightarrow	gauge bosons
quarks	leptons		\Rightarrow	fermions
g_3	g_2	g_1	\Rightarrow	g_{GUT}

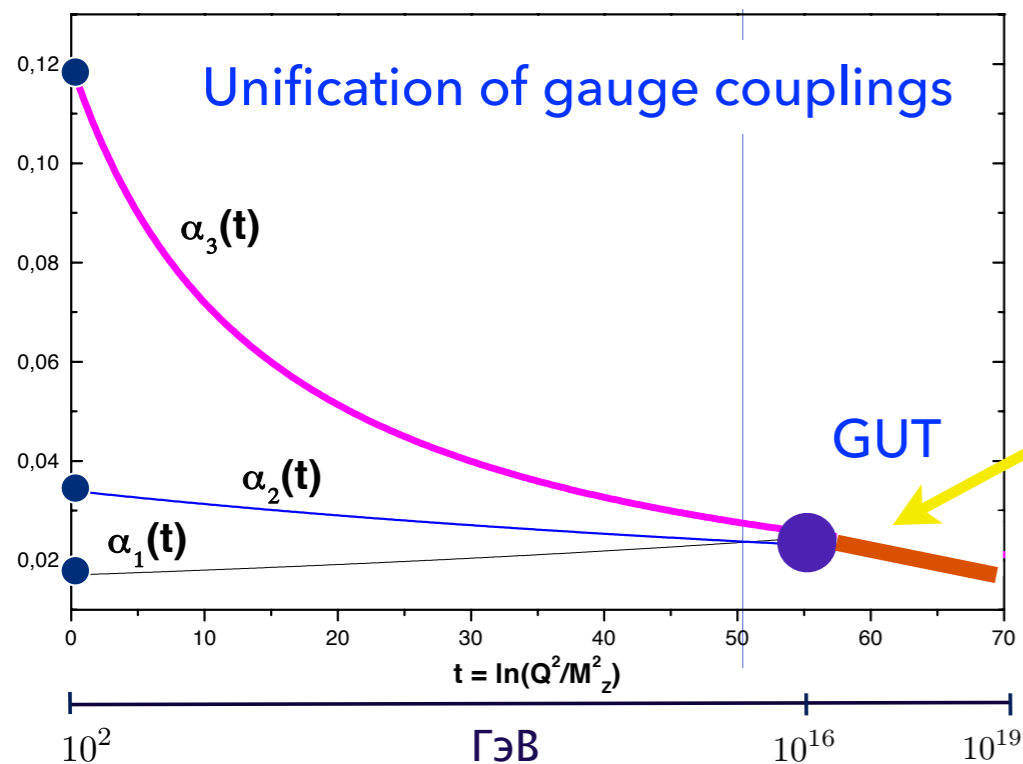

$$SU(3) \times SU(2) \times U(1) \subset G_{GUT}$$

Ex : $SU(5), SO(10), E(6), SU(5) \times U(1),$
 $SU(4) \times SU(2) \times SU(2), SO(10) \times U(1)$

Solves many problems of the SM:

- absence of Landau pole
- Decreases the number of parameters
- All particles in a single representation (**16** of SO(10))
- Unifies quarks and leptons -> spectrum and mixings from «textures»
- A way to **B** and **L** violation

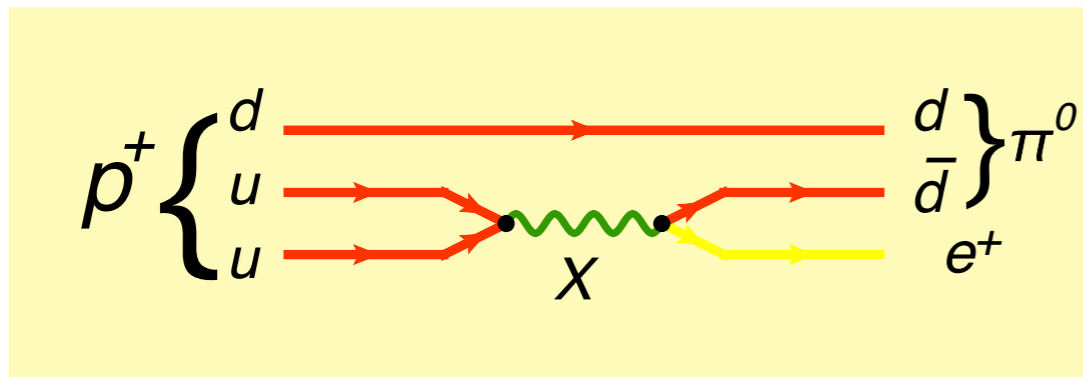

- Unification of the gauge couplings
- stabilization of the hierarchy



Low energy SUSY

Creates new problems:

- Hierarchy of scales $M_W/M_G \sim 10^{-14}$
- Large Higgs sector is needed for GUT symmetry breaking

Crucial predictions:

- Proton decay $P \rightarrow e^+ \pi, P \rightarrow \bar{\nu} K^+$
- Neutron-antineutron oscillations
- $|\Delta(B - L)| = 1$ ($|\Delta(B - L)| = 2$) processes

Experiment:

mean life time $> 10^{31} - 10^{33}$ years

$$\tau_{proton} \sim 10^{32} \text{ years}$$

$$\tau_{Universe} \approx 14 \cdot 10^9 \text{ years}$$

NEW SYMMETRIES

- Appear in some GUT models
- Inspired by string models

Used as possible BSM signal with energetic single jet or dijet events

EXTRA U(1)', SU(2)'

Used as possible Dark matter candidate - Dark photon

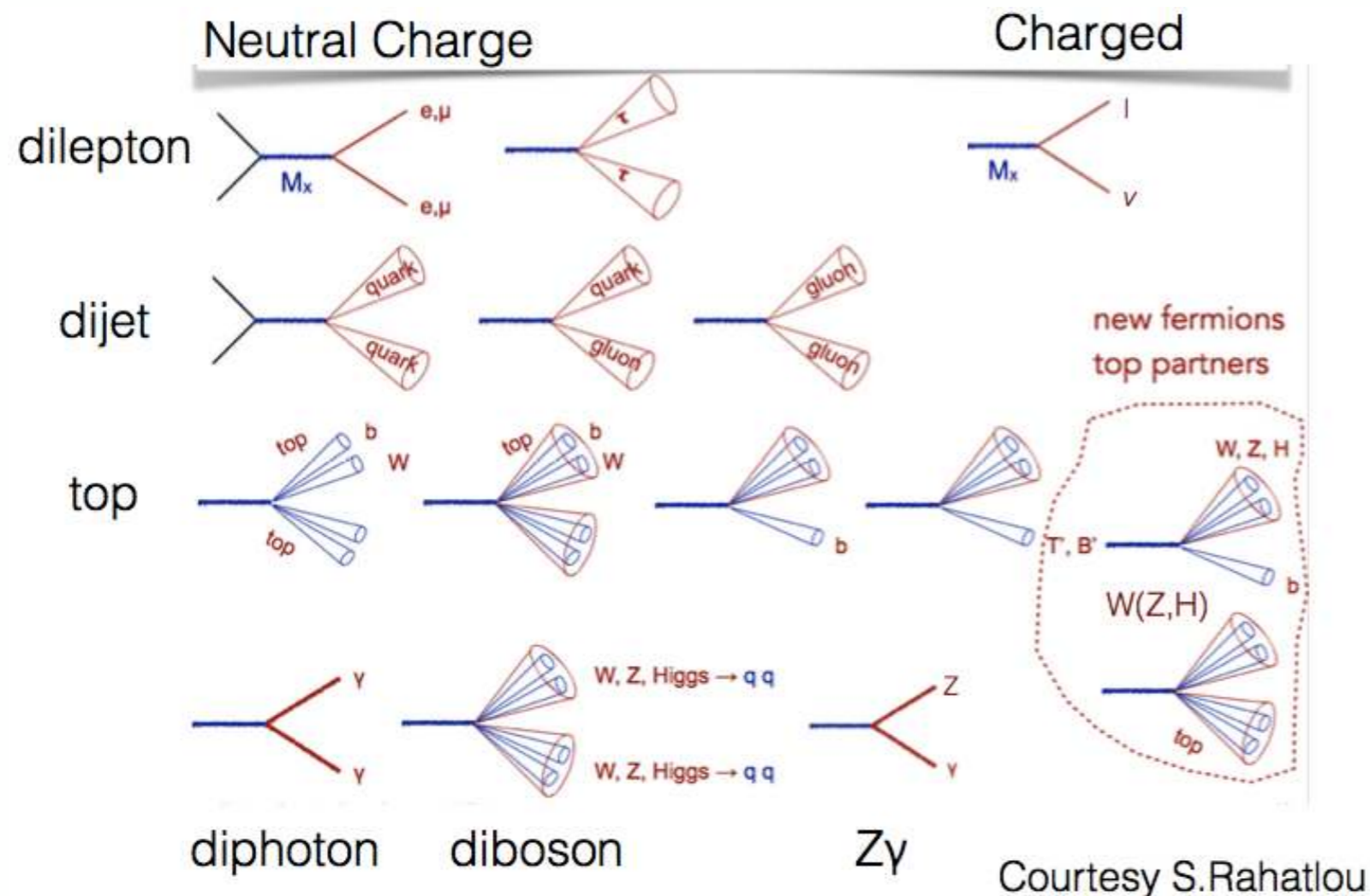

Mixture of a usual EM U(1) photon and a new U(1)' one

$$\mathcal{L} \sim F_{\mu\nu} F'^{\mu\nu}$$

Dedicated experiment to look for conversion of a usual photon into a dark one

Experiment

- Search for Z' (Di-muon events)
- Search for W' (single muon/ jets)
- Search for resonance decaying to t - \bar{t}
- Search for diboson resonances
- Monojets + invisible

Same Flavor Opposite Sign ($ee, \mu\mu, \tau\tau$)

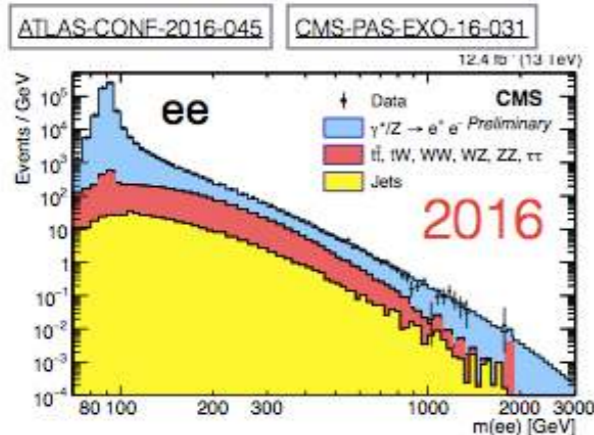

Same Sign ($ee, \mu\mu$) Z'_{SSM} (3% width) > 4 TeV
 Z'_ψ (0.5% width) > 3.36 TeV

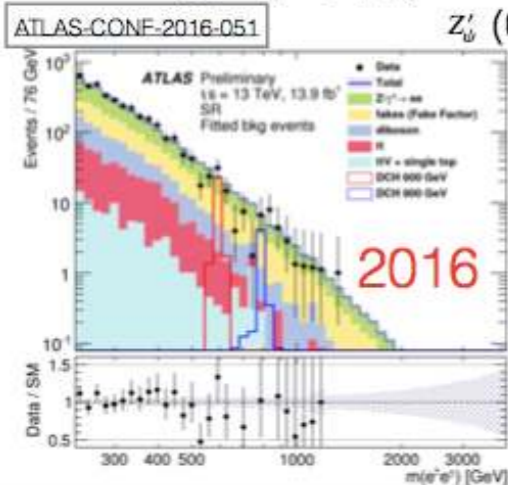

95% CL
exclusion limit

$H_R^{\pm\pm} > 420$ GeV
 $H_L^{\pm\pm} > 570$ GeV

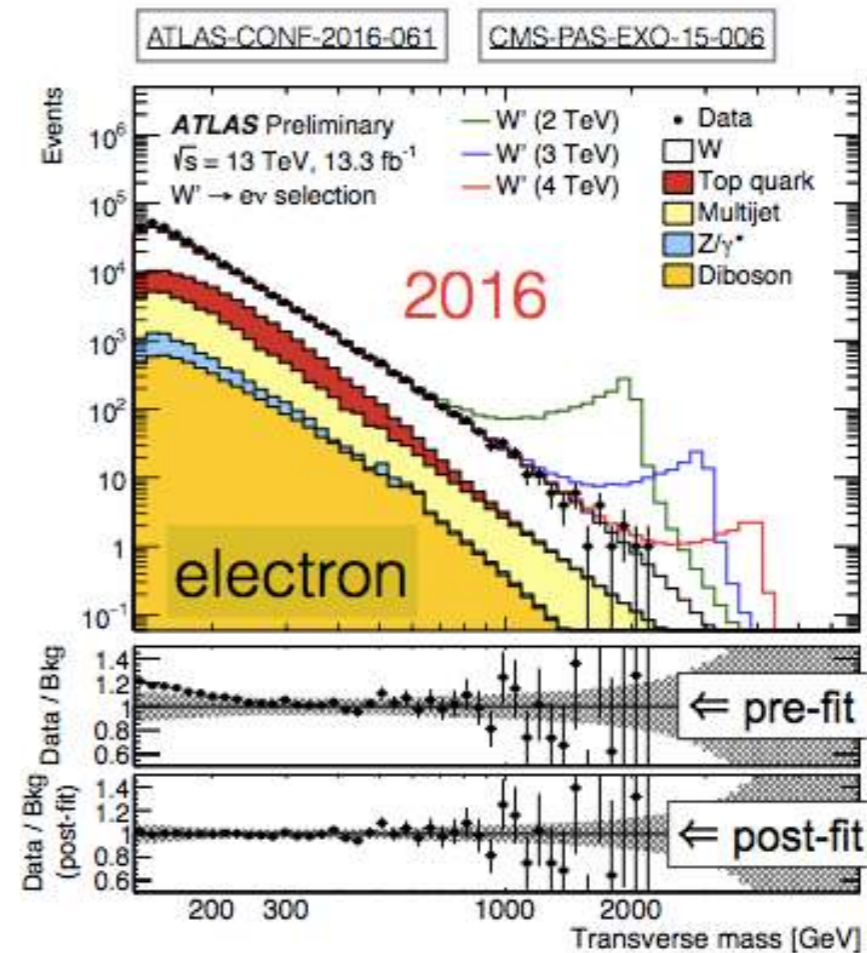

SSM $W' > 4.74$ TeV

No indication so far - experimental limits on Z' and W' masses around few TeV

NEW PARTICLES

Is it the SM Higgs boson or not?

What are the alternatives?

How to probe?

- Probe deviations from the SM Higgs couplings

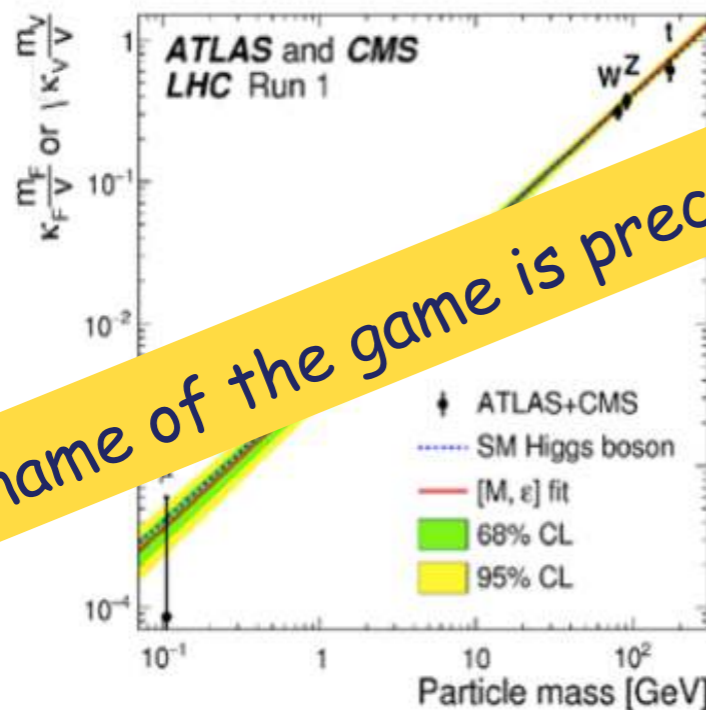

The name of the game is precision

- The Higgs physics has already started
- This is the task of vital importance.
- May require the electron-positron collider

EXTENDED HIGGS SECTOR



- A. Singlet extension
- B. Higgs doublet extension
- C. Higgs triplet extension

- Perform direct search for additional scalars

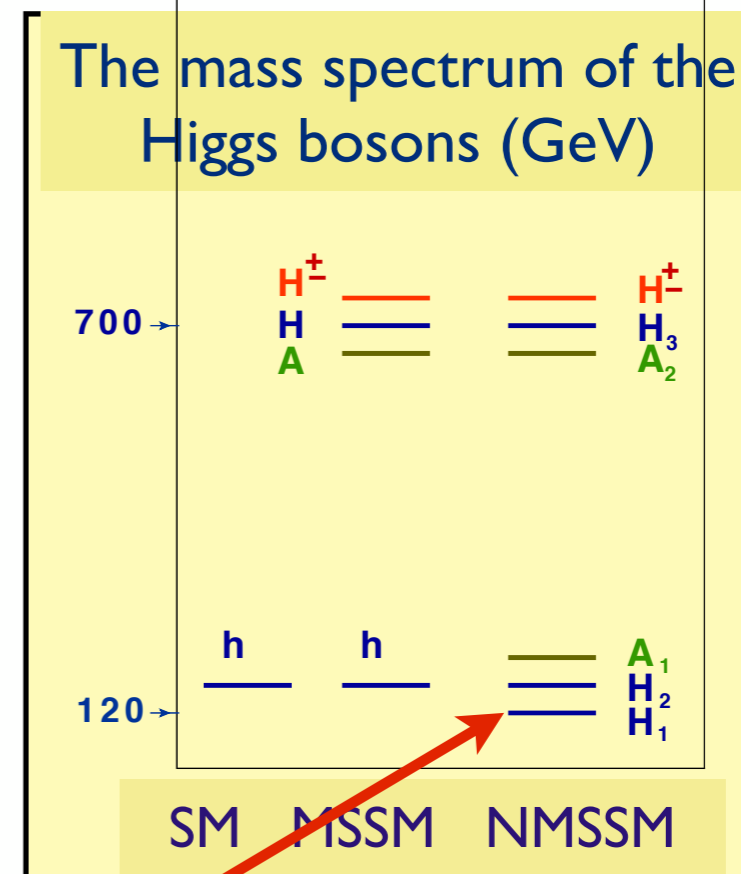

We may have found one of these states

PRECISION PHYSICS OF THE HIGGS BOSONS

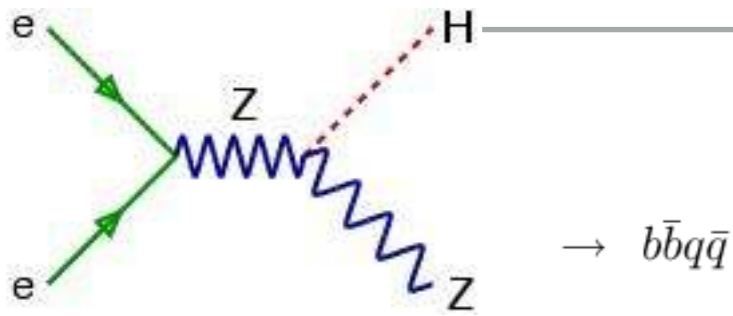

$ee \rightarrow HZ$ diff. decay channels

Int Linear Collider

$\rightarrow W^+W^-qq$

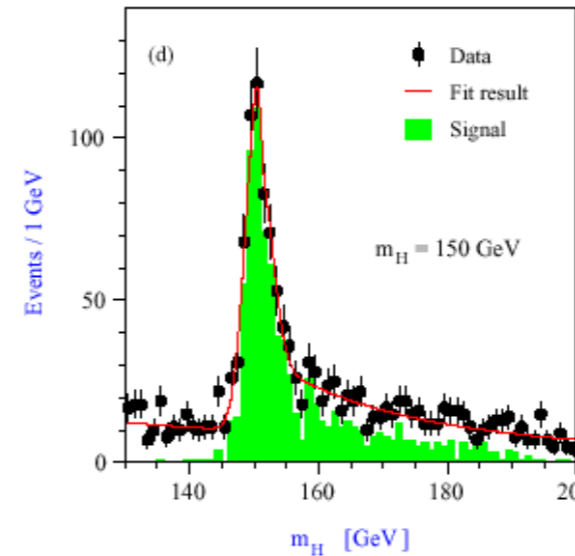
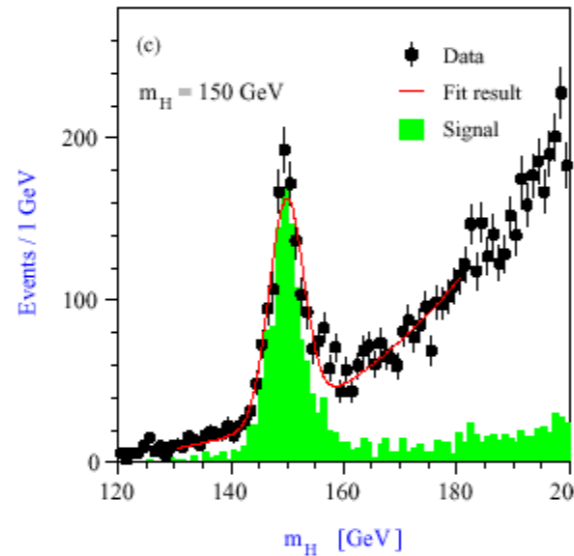
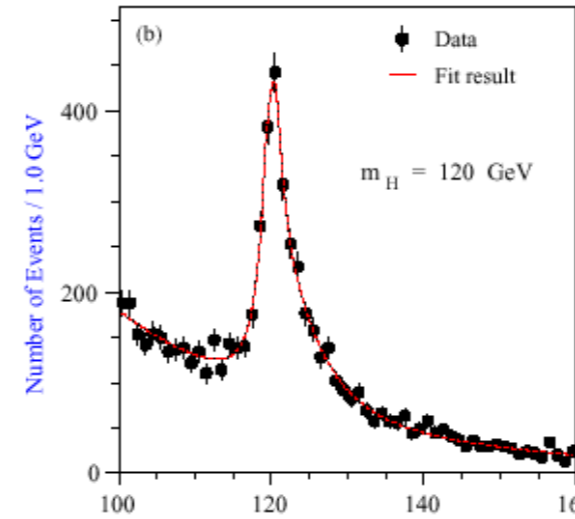
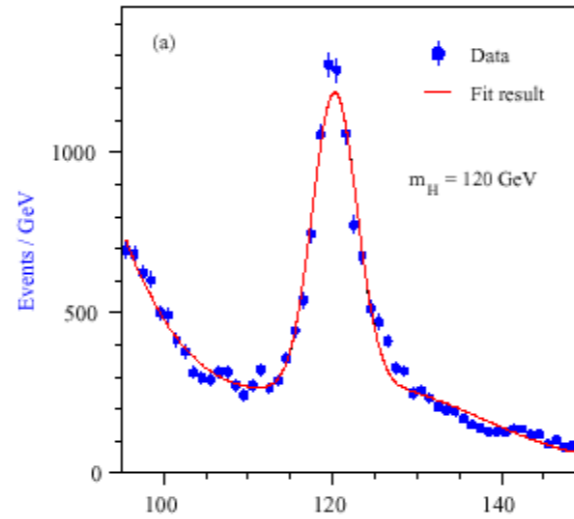

$\rightarrow qq\bar{l}^+l^-$

$\Delta m_H = 40 \text{ MeV}$

$\rightarrow W^+W^-l^+l^-$

$\Delta m_H = 70 \text{ MeV}$

Coupling Precision

LHC 300 fb⁻¹ x 2

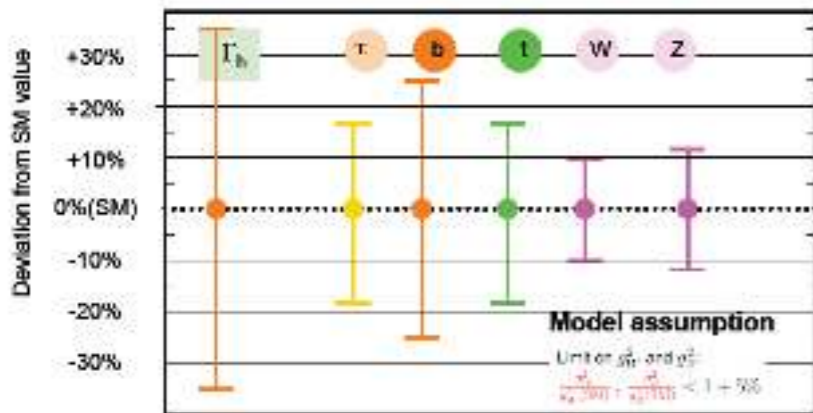

Coupling Precision

ILC

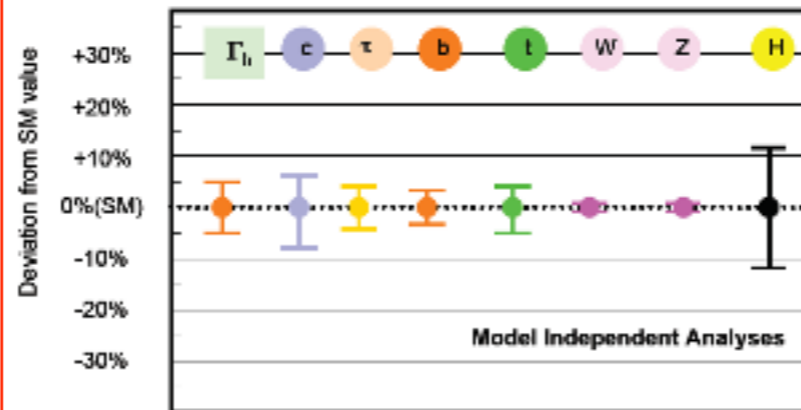

SUSY or 2HDM

ILC

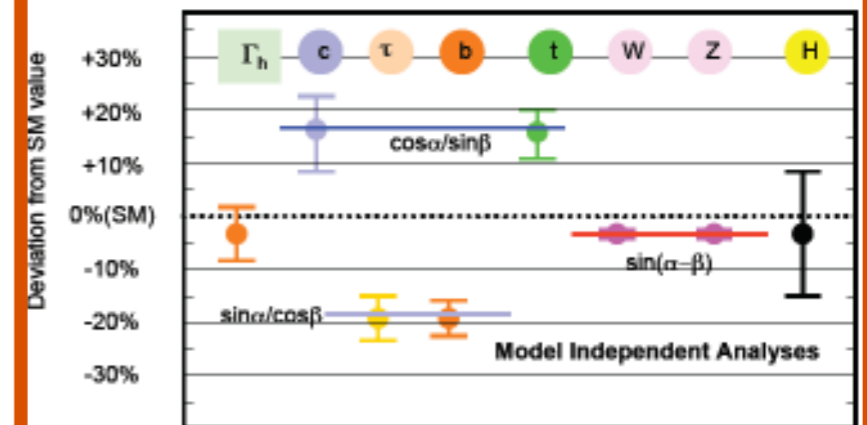

Higgs $\rightarrow hh \rightarrow bb\tau\tau$

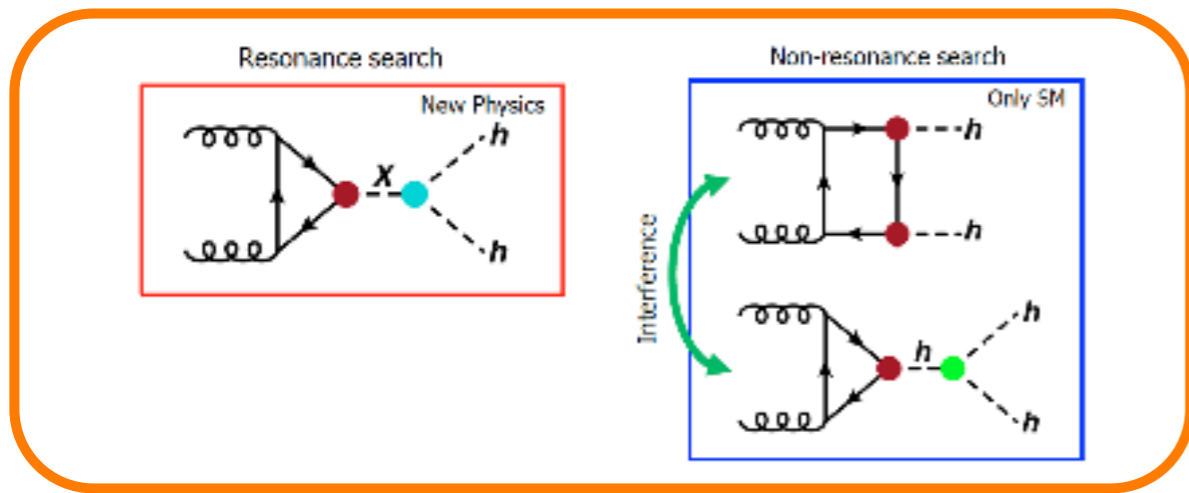

Heavy Higgs $\rightarrow ZZ \rightarrow 4l$

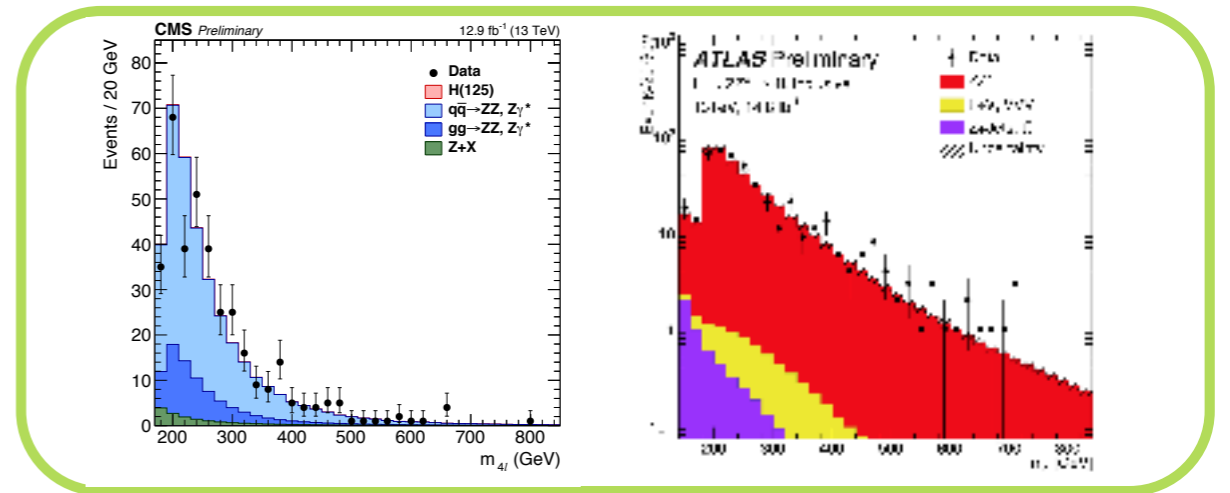

Resonant

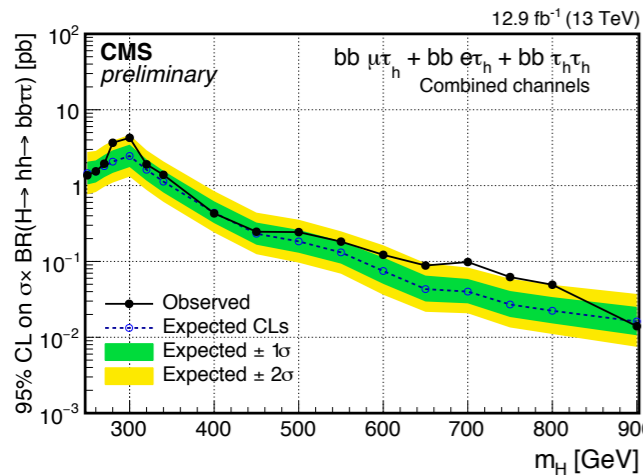

Non-Resonant

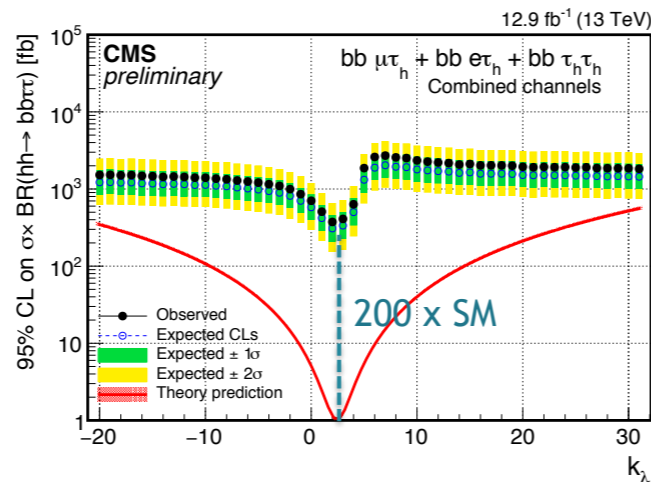

Charged Higgs

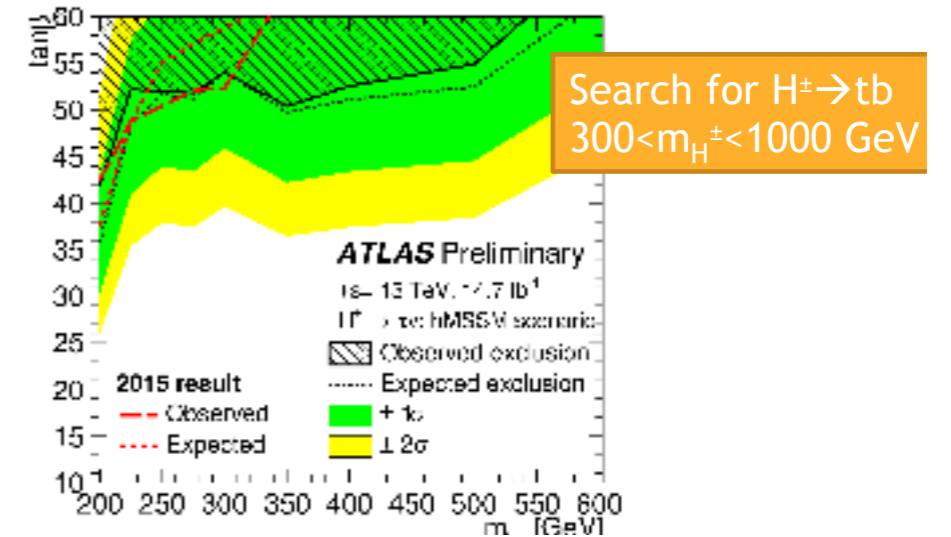

Heavy Higgs $\rightarrow \tau\tau$

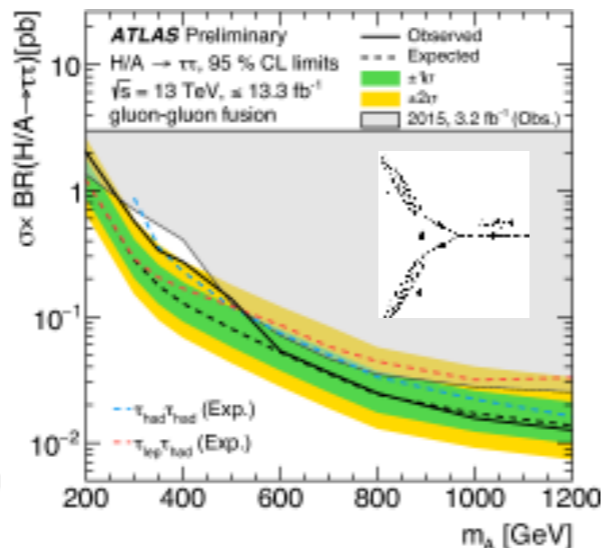
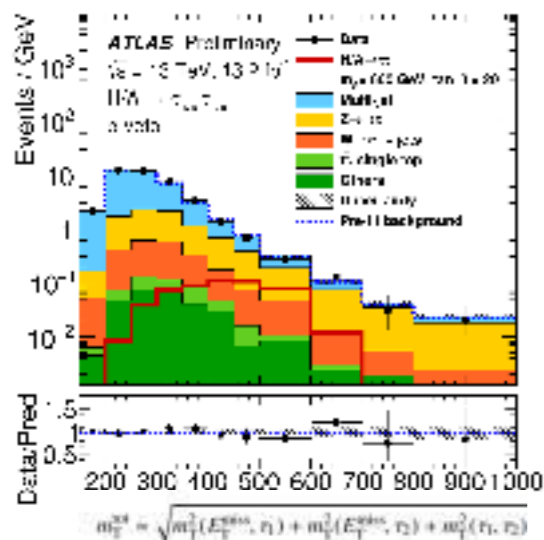

Search for $H^\pm WZ$

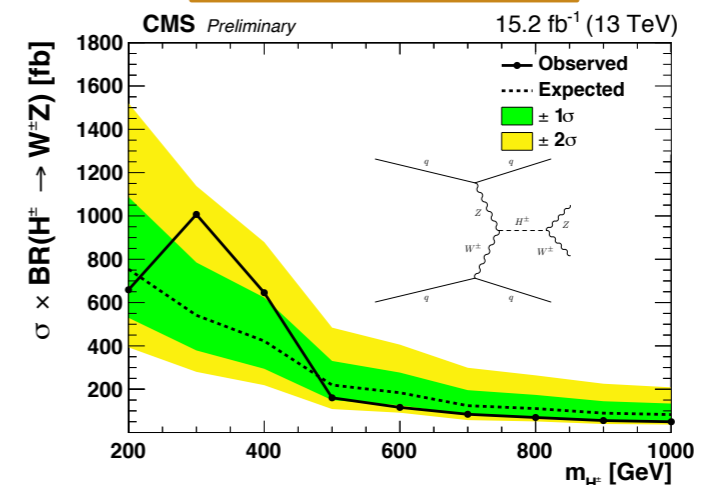

NEW PARTICLES

AXION OR AXION-LIKE PARTICLES

Javier Redondo, EPS HEP 2017

- CP violation in QCD sector: CKM angle $\delta_{13} = 1.2 \pm 0.1$ rad AND flavour-neutral phase $\theta = \theta_{\text{QCD}} + N_f \delta$

$$\mathcal{L}_{\text{SM}} \in -\bar{q}_L \begin{pmatrix} m_u e^{i\delta/2} & 0 & \dots \\ 0 & m_d e^{i\delta/2} & \dots \\ 0 & 0 & \dots \end{pmatrix} \begin{pmatrix} u \\ d \\ \dots \end{pmatrix}_R - \frac{\alpha_s}{8\pi} G\tilde{G}\theta_{\text{QCD}}$$

Axial anomaly

The θ -angle produces flavour-neutral CP violation like Electric Dipole Moments

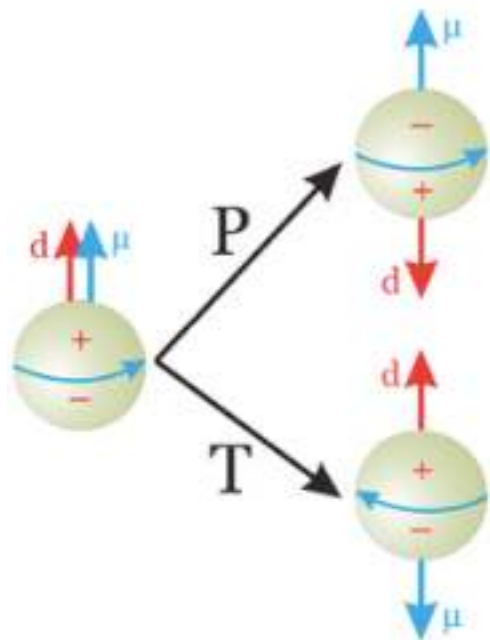

- Neutron EDM (Guo 1502.02295)

$$d_n = -4 \times 10^{-3} \times \theta \text{ [e fm]}$$

- Experimental upper limit (Grenoble hep-ex/0602020)

$$|d_n| < 3 \times 10^{-13} \text{ [e fm]}$$

- Why is $\theta < 10^{-10}$?

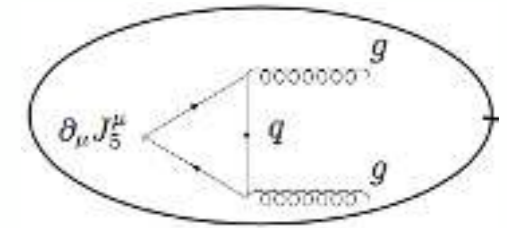

- Any theory promoting θ to a dynamical field, $\theta(t, \mathbf{x})$, will dynamically set $\theta \rightarrow 0$ after some time...

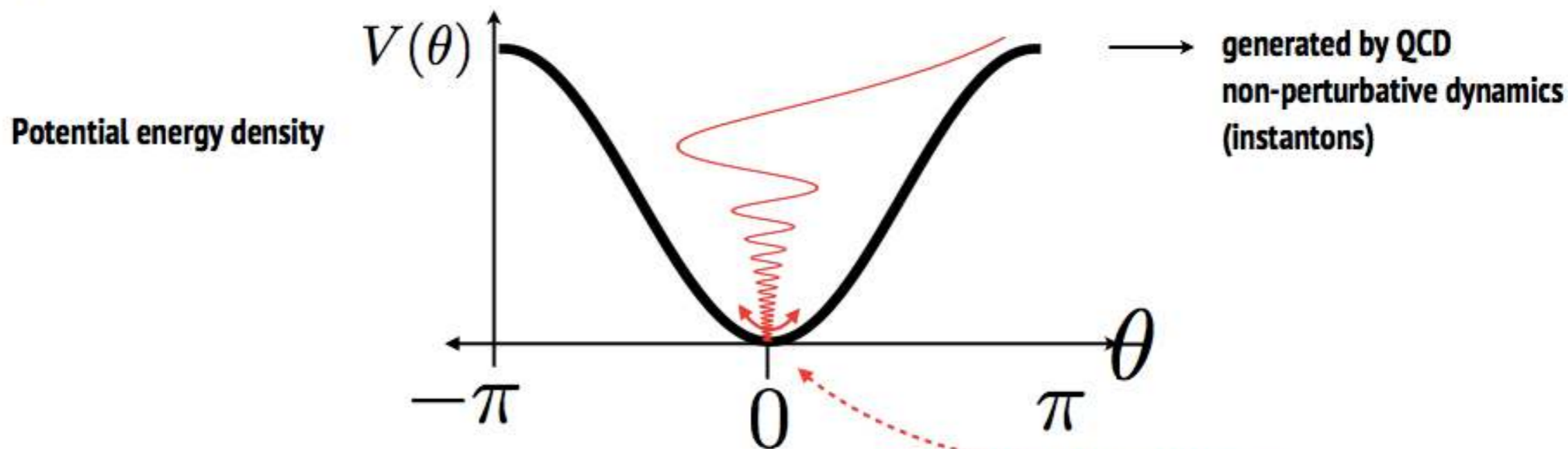

- PQ Mechanism: Global U(1) axial symmetry, spontaneously broken, colour anomalous \rightarrow Goldstone boson

$$\mathcal{L}_\theta = \frac{1}{2}(\partial_\mu\theta)(\partial^\mu\theta)f_a^2 - \frac{\alpha_s}{8\pi}G_{\mu\nu a}\tilde{G}_a^{\mu\nu}\theta$$

New Spontaneous symmetry breaking [energy] scale f_a

Canonically normalised θ field is the QCD AXION! $a(x) = \theta(x)f_a$

WW Axion

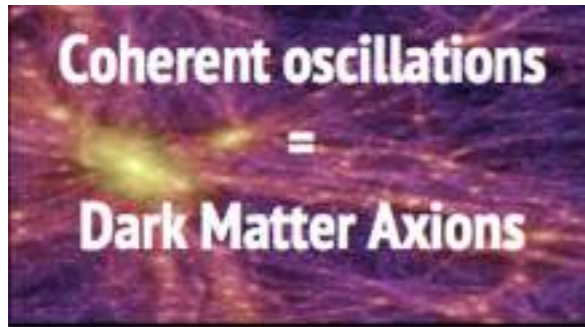

- Some amount of axion Dark matter is unavoidable!

- Axion DM scenarios



Excluded by Lab+Astro

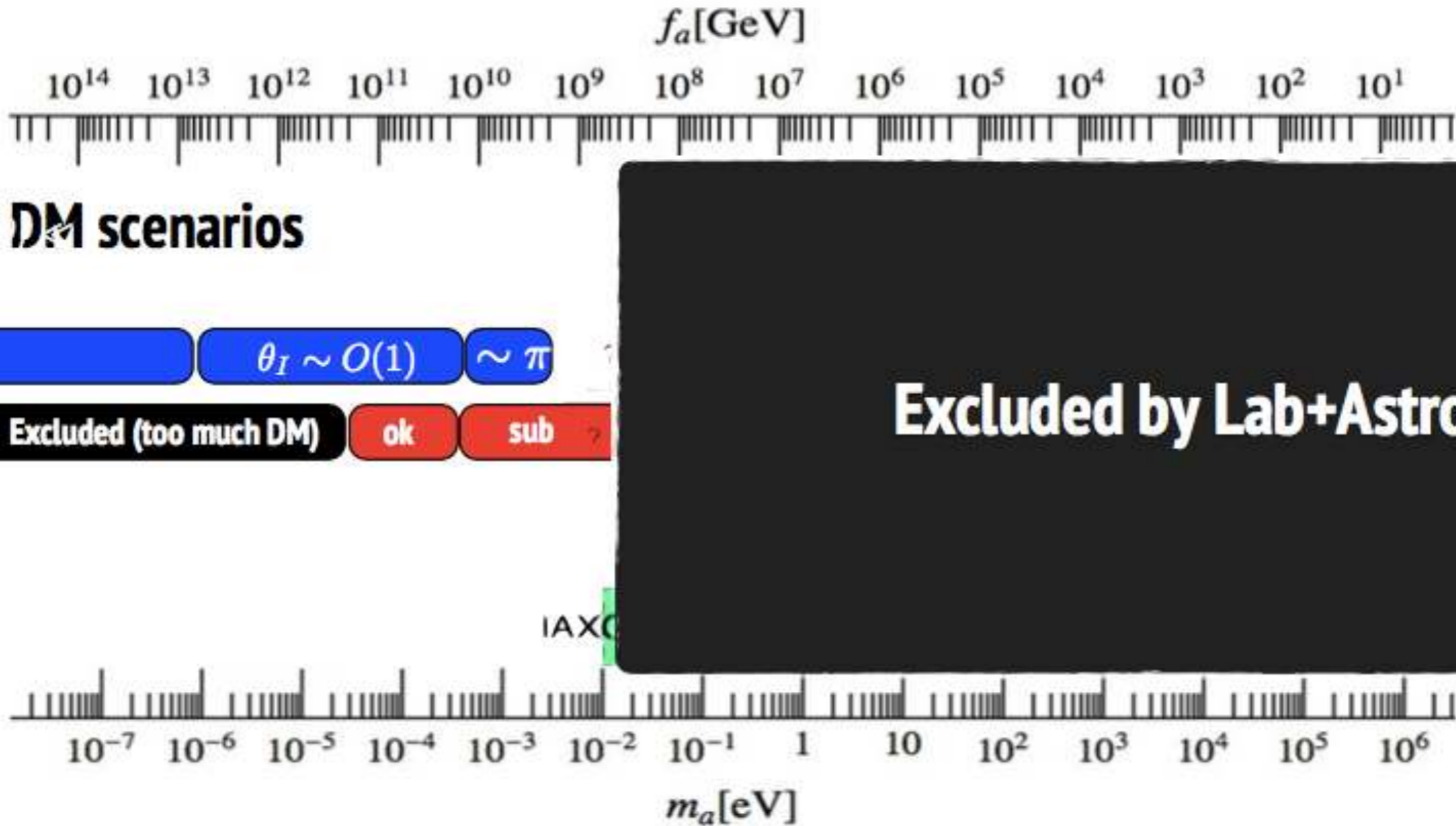

- Less minimal axion models have further possibilities

NEW PARTICLES

- Number of Generations=3?
- Why 3 copies?
- The necessary condition for the baryon asymmetry of the Universe - CP violation
- CP in the SM comes from the non-zero phase in the quark (and lepton) mixing matrices
- Non-zero phase appears only if the number of generations $N \geq 3$

- The width of the Z-boson (LEP)

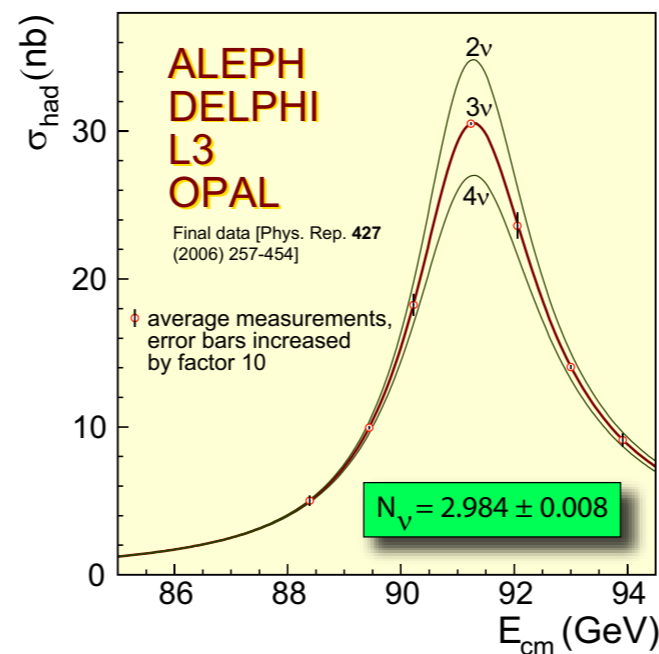

NEUTRINOS

- The CMB spectrum (Planck)

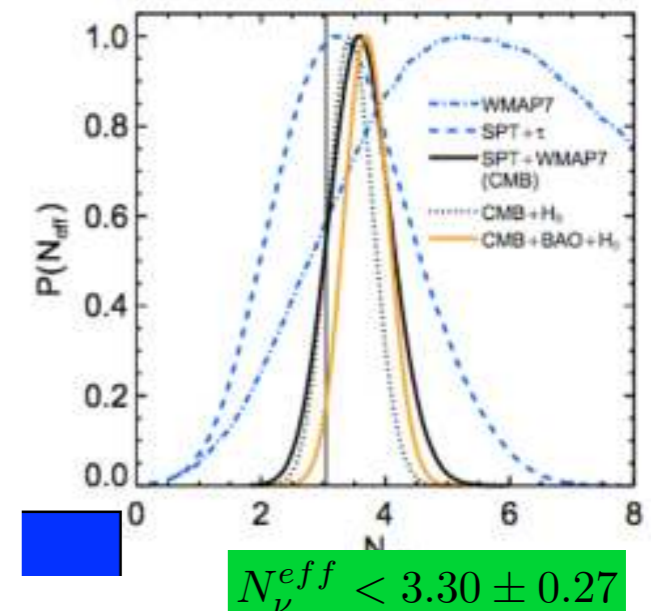

- The fourth generation of quarks is excluded also by precision measurement of rare decays
- Do we see all neutrinos or there are heavy right-handed ones? (Majorana)
- Are there any new sterile neutrinos? (To release the constraints from LSND/MiniBoone and reactor anomaly, etc)

NEW PARTICLES

NEUTRINOS

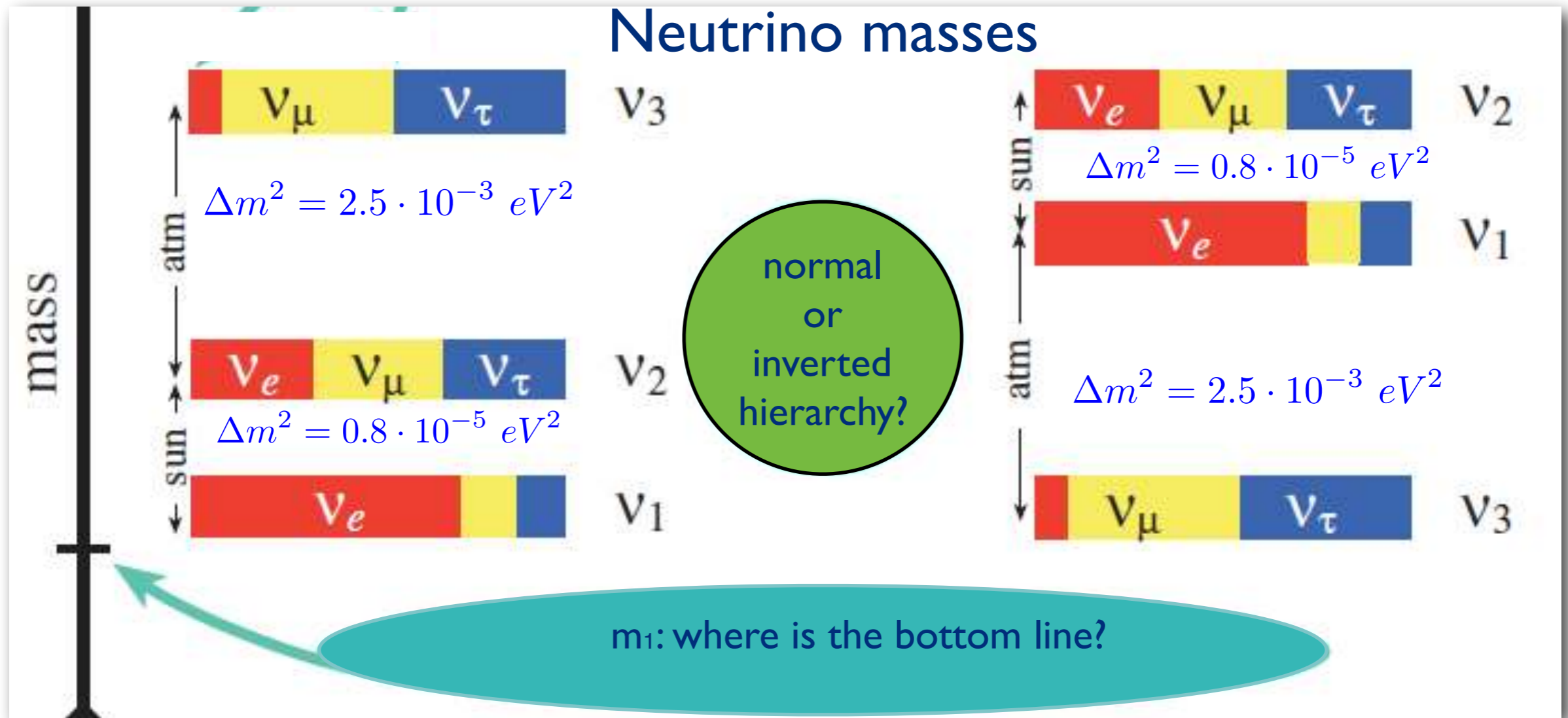

$$\sum m_\nu < 0.23 eV$$

$$m_{\nu_e} < 2 eV$$

$$m_{\nu_e} < 0.2 eV$$

cosmology: the CMB spectrum

Planck

β -decay
Troitsk-Mainz

KATRIN

$$\nu_D = \begin{pmatrix} \nu_L \\ \nu_R \end{pmatrix} \quad \nu_{M_1} = \begin{pmatrix} \xi_1 \\ \xi_1^* \end{pmatrix}, \quad \nu_{M_2} = \begin{pmatrix} \xi_2 \\ \xi_2^* \end{pmatrix}$$

$$\nu_D \neq \nu_D^* \\ m_{\nu_L} = m_{\nu_R}$$



$$\nu_M = \nu_M^* \\ m_{\nu_{M_1}} \neq m_{\nu_{M_2}}$$

$0\nu\beta\beta$ decay

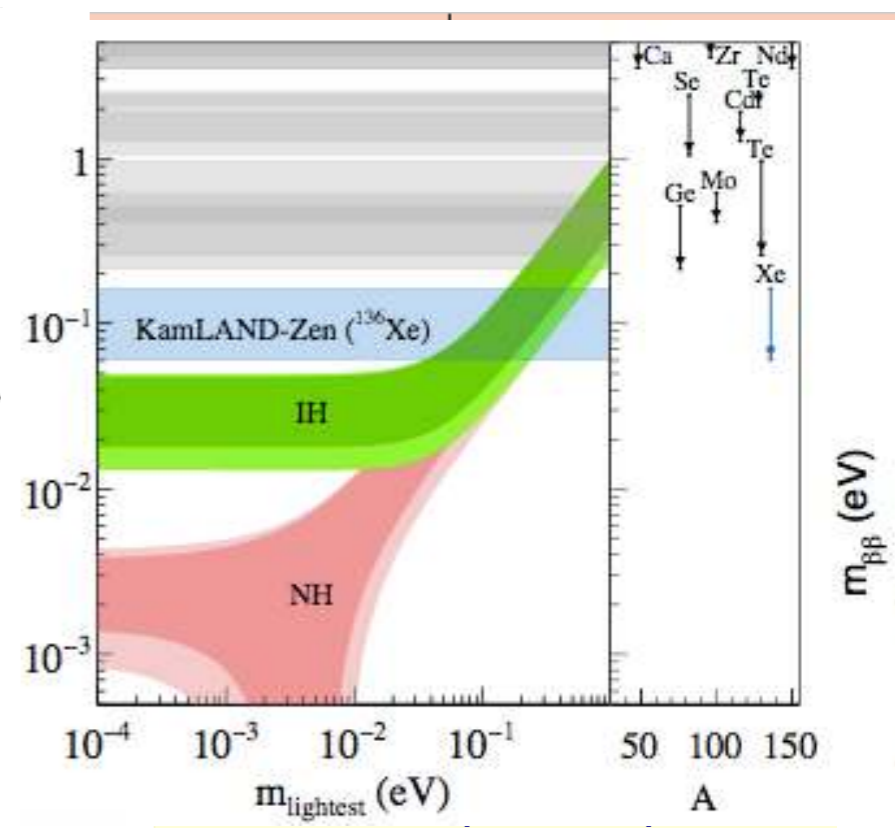
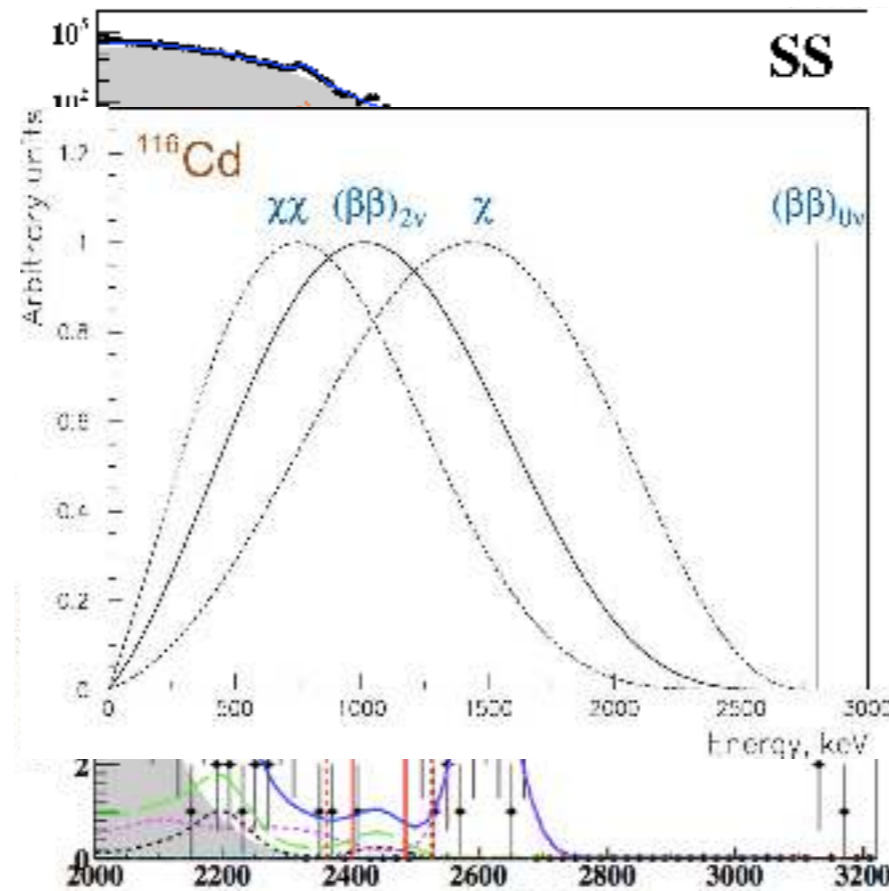
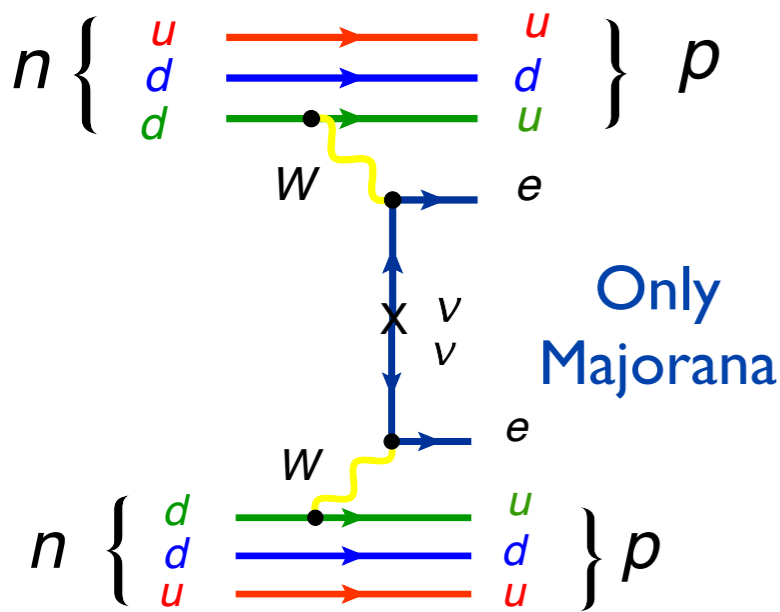

No evidence for sterile neutrinos

Various exps interpreted within 4 neutrino framework

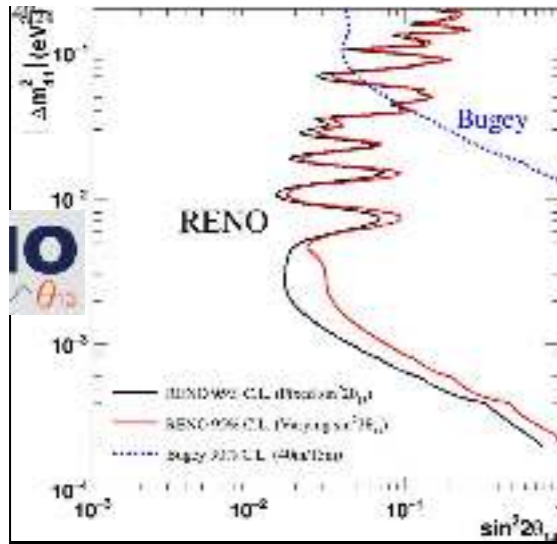

Oscillation channels are related:

$$P_{\nu_e \rightarrow \nu_e} \approx 1 - 2|U_{e4}|^2(1 - |U_{e4}|^2)$$

$$P_{\nu_\mu \rightarrow \nu_\mu} \approx 1 - 2|U_{\mu4}|^2(1 - |U_{\mu4}|^2)$$

$$P_{\nu_\mu \rightarrow \nu_e} \approx 2|U_{e4}|^2|U_{\mu4}|^2$$

for $4\pi E/\Delta m_{41}^2 \ll L \ll 4\pi E/\Delta m_{31}^2$

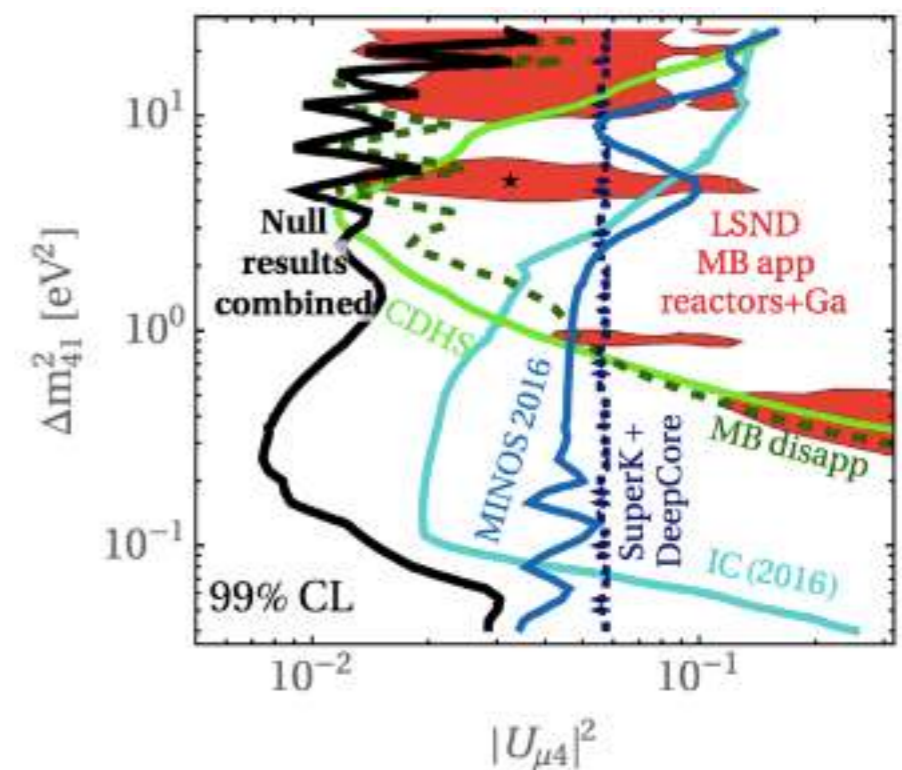
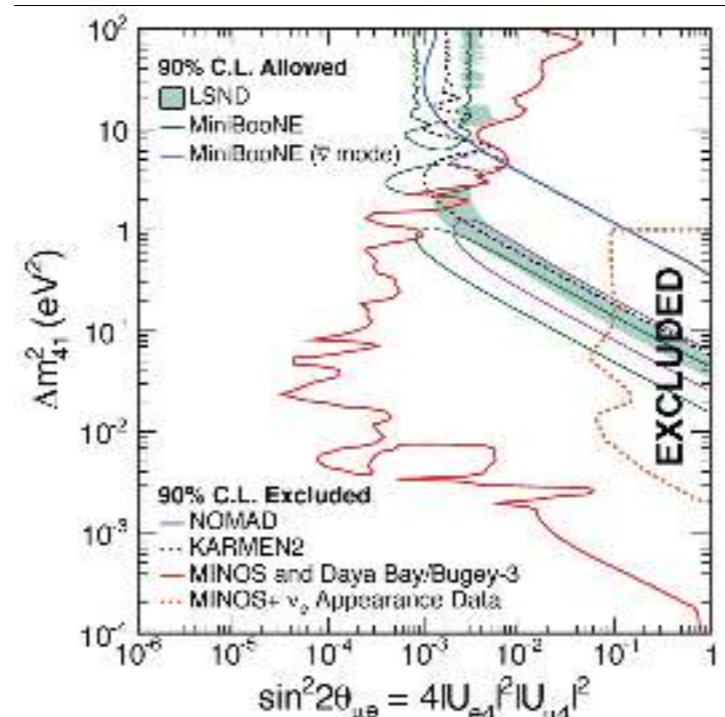
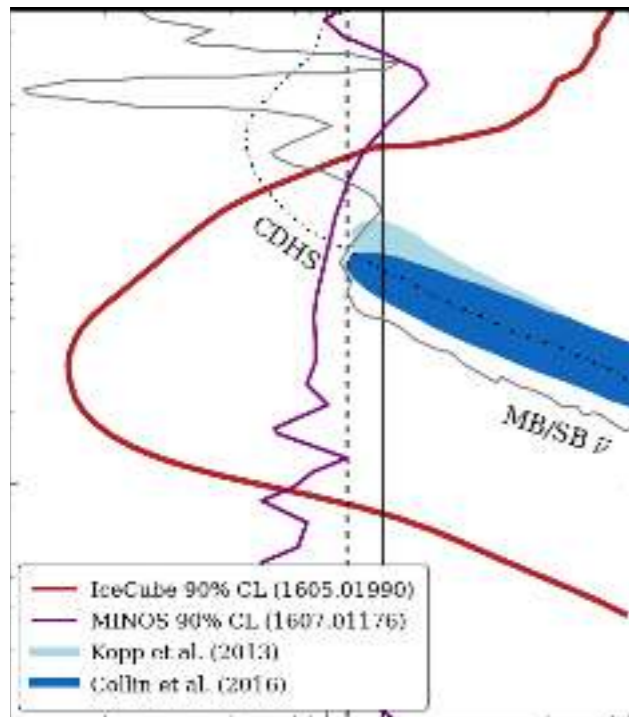

NEW PARTICLES

DARK MATTER

The Dark Matter is made of:

- Macro objects – **Not seen**
- New particles – right heavy neutrino

Not from the SM

- axion (axino)
- neutralino
- sneutrino
- gravitino
- heavy photon
- heavy pseudo-goldstone
- light sterile higgs

might be invisible (?)

detectable in 3 spheres

less theory favorable

might be undetectable (?)

possible, but not related to the other models

Future DM searchers

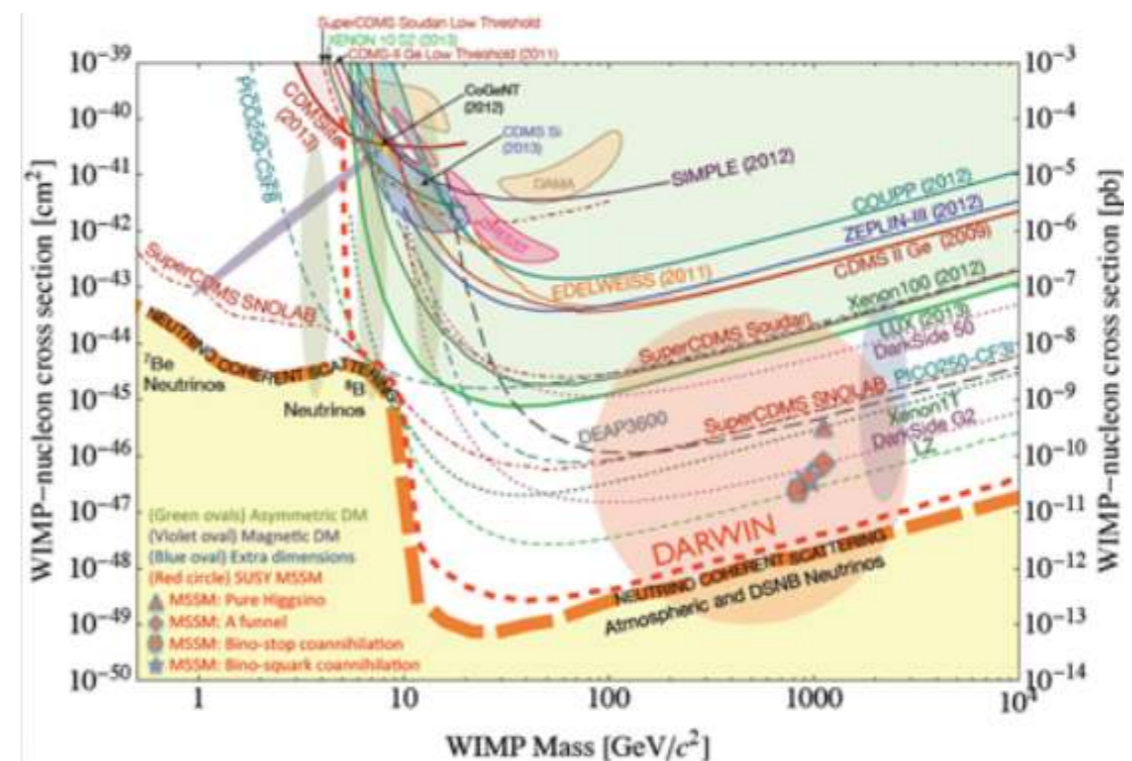
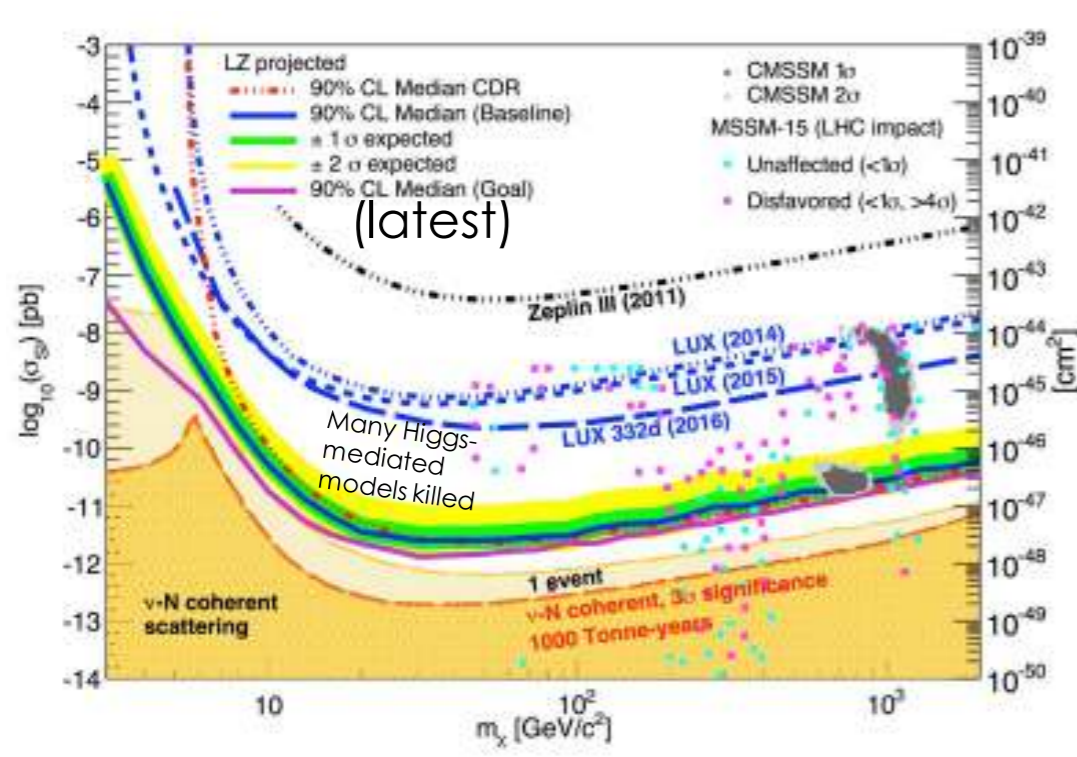

NEW DIMENSIONS

EXTRA SPACE DIM

$$1 + 3 \rightarrow 1 + n, n > 3$$

Motivations

1. String theory
 2. Interesting possibility that opens wide opportunities
- String theory suffers conformal anomalies that make it inconsistent.
 - Conformal anomaly cancels at $D=26$ for a bosonic string and $D=10$ for a fermionic string

Why don't we see extra dimensions

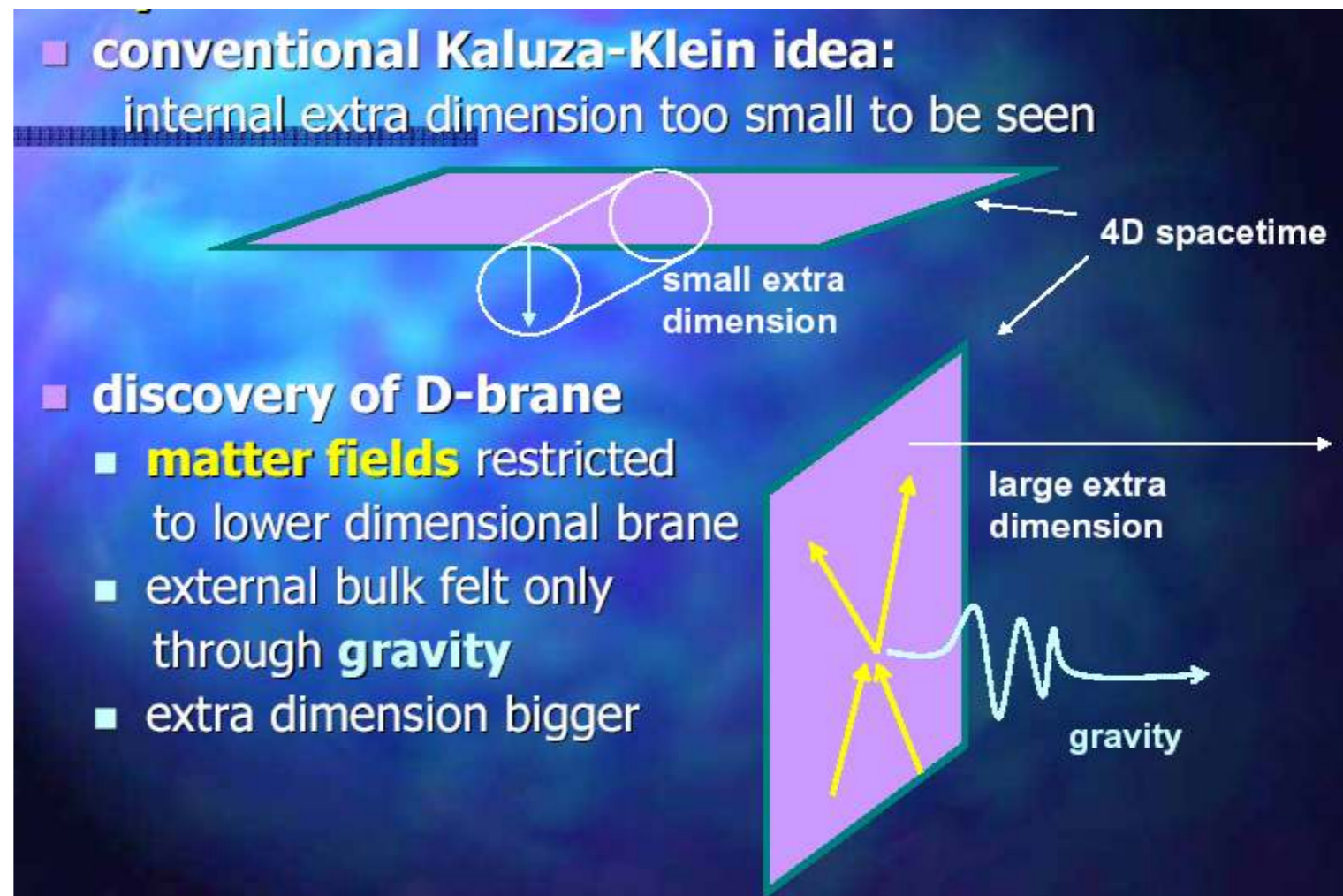

Accelerator signatures

- Gravitational radiation in the bulk => missing energy

Present LHC bounds $M_* \geq 3 - 5 \text{ TeV}$

- Massive string vibrations => resonances in dijet distribution

$$M_j^2 = M_0^2 + M_s^2 j$$

- Higher spin excitations of gluons with strong coupling
- present LHC limits
- Large TeV resonances

$M_k = M_s \sqrt{k}, k = 1, 2, \dots$

experimental bounds

$$R^{-1} \geq 4 \text{ TeV}$$

Vast phenomenology but no indication so far

- change of Newton's law at short distances (detectable only in case of 2 large extra dim)
- new short range forces (light scalars and gauge fields)

$$V(r) = -G \frac{m_1 m_2}{r} (1 + \alpha e^{-r/\lambda})$$

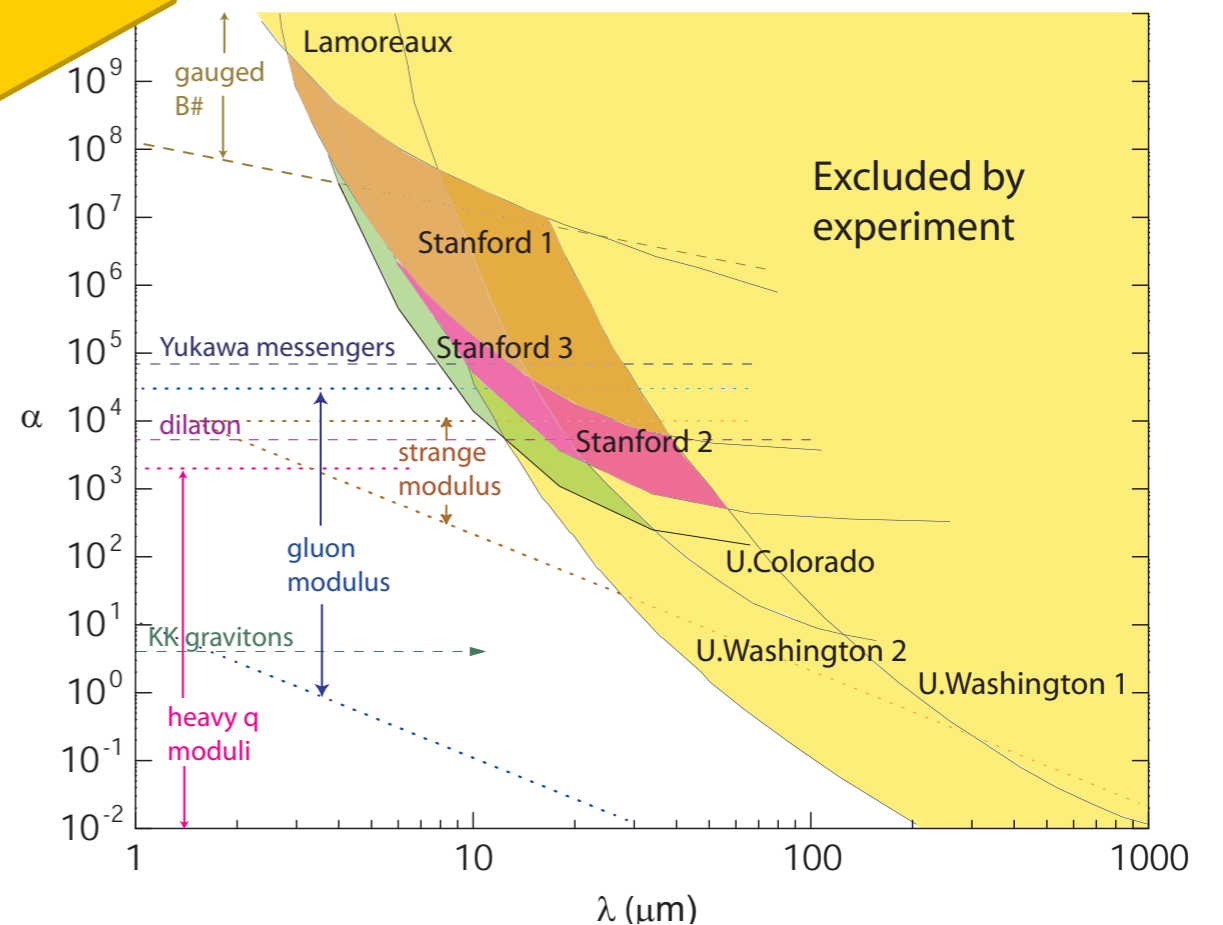

NEW PARADIGM

STRING THEORY

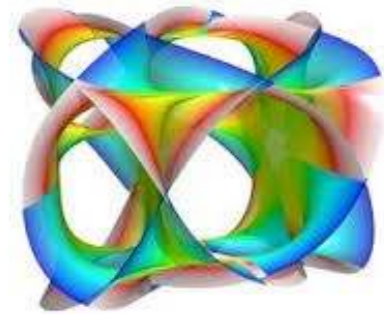

- * There are **five types of string theories** (IIA, IIB, I, two Heterotic)
- * All five string theories are only consistent in **10 space-time dimensions**
- * All five string theories have **world-sheet supersymmetry** and lead to **space-time-supersymmetry in 10 dimensions**
- * All five string theories are related and part of a single "theory": **M-theory**

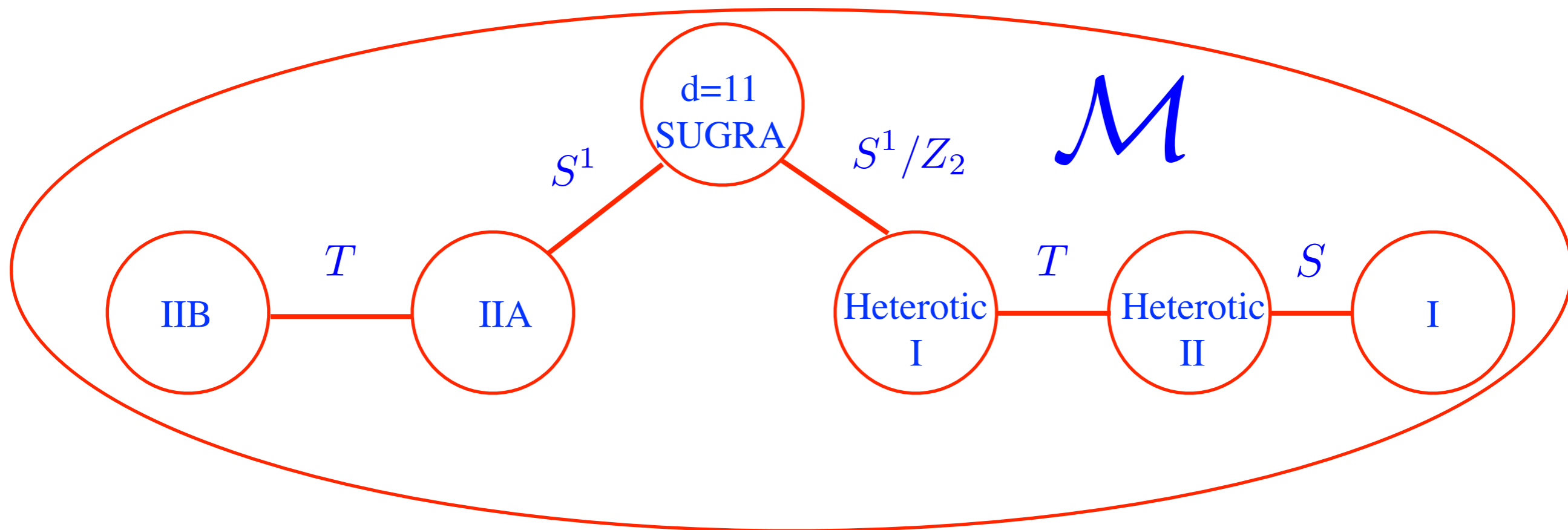

M-theory is a patchwork of the constituent theories plus many "rules".

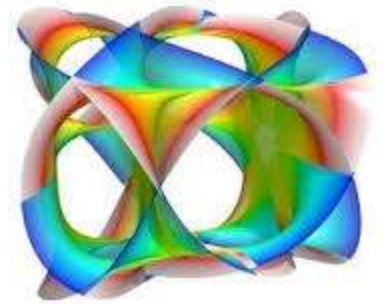

- Higgs from untwisted sector \Rightarrow gauge-Higgs unification

$$\lambda_{\text{top}} = g_{\text{GUT}} \Rightarrow m_{\text{top}} \sim \text{IR fixed point} \simeq 170 \text{ GeV}$$

- Yukawa couplings: hierarchies $\hat{=}$ le Froggatt-Nielsen

discrete symmetries \Rightarrow couplings allowed with powers of a scalar field

$$\lambda_n \sim \Phi^n \quad \langle \Phi \rangle \sim 0.1 M_s \rightarrow \text{hierarchies}$$

A single anomalous $U(1) \Rightarrow \langle \Phi \rangle \neq 0$ to cancel anomaly

• Potentially answering many questions
 • Requires SUSY for stabilization
 • Difficult to get low-energy outputs

- R-neutrinos: natural frame \Rightarrow seesaw mechanism

$$\langle h \rangle \nu_L \nu_R + M \nu_R \nu_R \quad \langle h \rangle = v \Rightarrow m_R \sim M; m_L \sim v^2 / M$$

- proton decay: problematic dim-5 operators

in general need suppression higher than M_s or small couplings

- SUSY in a hidden sector from the other $E_8 \rightarrow$ gravity mediation

NEW PARADIGM

BRAIN WORLD

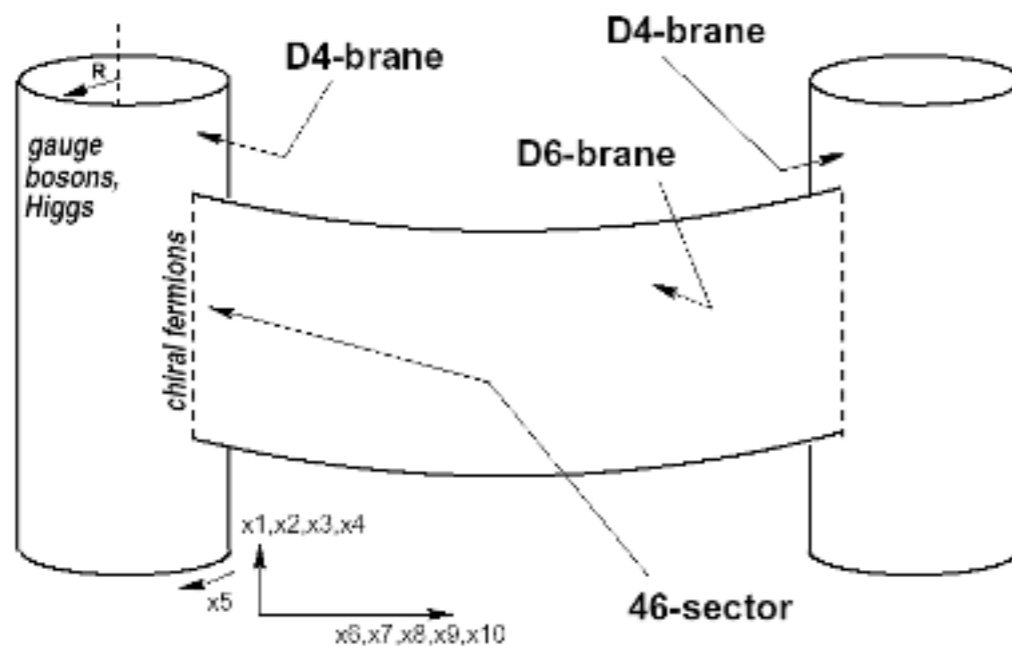

Q: Do we really live on a brane?

A: We have to check it

Q: Do we have good reasons to believe in it?

A: No, but it is appealing

Q: Why $D > 4$?

A: String theory loves it

Q: Is it what we believe in?

A: We believe in BIG deal

- ☑ LHC experiments are at the front line of mystery land: be patient
- ☑ Target #1: Higgs sector
- ☑ Target #2: Dark Matter
- ☑ Target #3: Neutrino sector
- ☑ Target #4: New physics (supersymmetry)
- ☑ Future development of HEP crucially depends on LHC outcome
- ☑ Complimentary searches for dark matter and insights in neutrino physics are of extreme importance
- ☑ The areas that were left behind come to the front: confinement, exotic hadrons, dense hadron matter