



Thunder K8S Pro // // S2882

Revision 1.00

Copyright © TYAN Computer Corporation, 2001-2003. All rights reserved. No part of this manual may be reproduced or translated without prior written consent from TYAN Computer Corp.

All registered and unregistered trademarks and company names contained in this manual are property of their respective owners including, but not limited to the following.

TYAN, Thunder K8S Pro are trademarks of TYAN Computer Corporation.

AMD, Opteron, and combinations thereof are trademarks of AMD Corporation.

AMI, AMIBIOS8 are trademarks of American Megatrends Inc.

Microsoft, Windows are trademarks of Microsoft Corporation.

SuSE, is a trademark of SuSE AG.

Linux is a trademark of Linus Torvalds

IBM, PC, AT, and PS/2 are trademarks of IBM Corporation.

Winbond is a trademark of Winbond Electronics Corporation.

Broadcom® is a trademark of Broadcom Corporation and/or its subsidiaries

ATI and Rage XL are trademarks of ATI Corporation

Silicon Image is a trademark of Silicon Image, Inc.

Information contained in this document is furnished by TYAN Computer Corporation and has been reviewed for accuracy and reliability prior to printing. TYAN assumes no liability whatsoever, and disclaims any express or implied warranty, relating to sale and/or use of TYAN products including liability or warranties relating to fitness for a particular purpose or merchantability. TYAN retains the right to make changes to product descriptions and/or specifications at any time, without notice. In no event will TYAN be held liable for any direct or indirect, incidental or consequential damage, loss of use, loss of data or other malady resulting from errors or inaccuracies of information contained in this document.



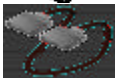











Table of Contents

Before you begin...	Page 4
Chapter 1: Introduction	
Congratulations	Page 5
Hardware Specifications	Page 5
Software Specifications	Page 6
Chapter 2: Board Installation	
2.00 Board Image	Page 8
2.01 Block Diagram	Page 9
2.02 Board Parts, Jumpers and Connectors	Page 10
2.03 Gigabit LAN_2 Front Panel LED Header (J1) and Gigabit LAN_1 Front Panel LED Header (J2)	Page 12
2.04 Front Panel Connector (J6)	Page 12
2.05 Clear CMOS Jumper (J8)	Page 13
2.06 SMBus_0 Connector (J11)	Page 13
2.07 USB Connector Headers (J12)	Page 14
2.08 10/100 LAN front Panel LED Header (J17)	Page 14
2.09 Chassis Intrusion Connector (J19)	Page 15
2.10 ZCR Connector (J22)	Page 15
2.11 COM2 Header (J23)	Page 16
2.12 PCI-X Bridge B (PCI 1 & PCI 2) PCI-X Speed Select Jumper (J24 / J39)	Page 16
2.13 PCI-X Bridge A (PCI 3 & PCI 4) force PCI Mode Jumper (J41)	Page 17
2.14 PCI-X Bridge A (PCI 3 & PCI 4 & SCSI7902 & BCM5704) PCI-X Speed Select Jumper (J43)	Page 17
2.15 SMDC Connector (J45)	Page 18
2.16 Onboard VGA Enable / Disable Jumper (J46)	Page 18
2.17 Onboard Gigabit Ethernet Enable / Disable Jumper (J52)	Page 19
2.18 Onboard 10/100 Ethernet Enable / Disable Jumper (J60)	Page 19
2.19 CPU_1 Fan Connector (P1_FAN) (J5)	Page 20
2.20 CPU_2 Fan Connector (P2_FAN) (J47)	Page 20
2.21 FAN 1 Chassis Fan Connector (J44)	Page 21
2.22 FAN 2 Chassis Fan Connector (J48)	Page 21
2.23 FAN 3 Chassis Fan Connector (J4)	Page 22
2.24 FAN 4 Chassis Fan Connector (J9)	Page 22
2.25 FAN 5 Chassis Fan Connector (J3)	Page 23
2.26 OEM Reserved Connectors and Jumpers	Page 23
2.27 Installing the Processor(s)	Page 23
2.28 Heatsink Retention Frame Installation	Page 24
2.29 Thermal Interface Material	Page 25
2.30 Heatsink Installation Procedures	Page 26
2.31 Finishing Installing Heatsink	Page 27
2.32 Tips on Installing Motherboard in Chassis	Page 28
2.33 Installing the Memory	Page 29
2.34 Attaching Drive Cables	Page 31
2.35 Installing Add-In Cards	Page 33
2.36 PCI Riser Cards Supported on S2882 K8S	Page 34
2.37 Connecting External Devices	Page 34
2.38 Installing the Power Supply	Page 35
Chapter 3: BIOS	
3.00 BIOS Setup Utility	Page 36
3.01 BIOS Menu Bar	Page 37

3.02	BIOS Legend Bar	Page 37
3.03	BIOS Main Menu	Page 38
3.04	BIOS Advanced Menu	Page 39
3.05	BIOS PCI/PnP Menu	Page 52
3.06	BIOS Boot Settings Menu	Page 54
3.07	BIOS Security Menu	Page 60
3.08	BIOS Chipset Setting Menu	Page 61
3.09	BIOS Power Menu	Page 67
3.10	BIOS Exit Menu	Page 68
Chapter 4: Diagnostics		Page 69
Appendix I: Glossary		Page 70
Appendix II: SMDC Information		Page 75
Technical Support		Page 76

Before you begin...
Check the box contents!

The retail motherboard package should contain the following:

	1x Thunder K8S Pro motherboard
	1x 34-Pin floppy drive cable
	1x LVD SCSI cable (if optional SCSI included)
	4 x SATA cable
	2 x SATA Drive Power Adapter
	2 x Ultra-DMA-100/66 IDE cable
	1 x Cable set: 9-pin Serial and 25-pin Parallel
	1 x Thunder K8S Pro user's manual
	1 x Thunder K8S Pro Quick Reference guide
	1 x TYAN driver CD
	1 x LSI SCSI driver diskette (if optional SCSI included)
	1x Silicon Image SiI3114 SATA RAID driver diskette
	1x Silicon Image SiI3114 SATA Link driver diskette
	1 x I/O shield
	2 x CPU Retention Frame

If any of these items are missing, please contact your vendor/dealer for replacement before continuing with the installation process.

Chapter 1: Introduction

Congratulations

You are now the owner of the ideal solution for rackmount servers, large computer clusters, or pedestal server needs. The Tyan Thunder K8S Pro features support for Dual AMD Opteron processor(s), two channel Gigabit Ethernet, one 10/100 Ethernet and Serial ATA (SATA).

Remember to visit TYAN's Website at <http://www.TYAN.com>. There you can find information on all of TYAN's products with FAQs, online manuals and BIOS upgrades.

Hardware Specifications

Processor

Dual μ PGA 940-pin ZIF sockets
Supports up to two AMD Opteron™ processors
Onboard VRM, 4-phase PWM
128-bit DDR dual-channel memory controller integrated in CPU

Chipset

AMD-8131™ HyperTransport™ PCI-X Tunnel
AMD-8111™ HyperTransport™ I/O Hub
Winbond W83627HF Super I/O chip
Analog Devices ADM1027 Hardware Monitoring IC

Memory

128-bit DDR dual-channel memory bus
Total eight 184-pin 2.5-Volt DDR DIMM sockets (4 on CPU1 and 4 on CPU2)
Supports up to 16 Gigabyte Registered DDR
Supports ECC type memory modules
Supports PC2700, PC2100 and PC1600 DDR

Expansion Slots

2 Independent PCI-X buses from AMD-8131

- PCI-X bridge A supports 64-bit 133 / 100 / 66 / 33 MHz with two 3.3-Volt PCI-X slots
- PCI-X bridge B supports 64-bit 133 / 100 / 66 / 33 MHz with two 3.3-Volt PCI-X slots

One legacy 32-bit 33MHz PCI slot (5v) from AMD-8111
Total of five usable slots

Integrated Enhanced IDE Controller

Provides two IDE dual-drive ports for up to two IDE devices
Supports up to ATA-133 IDE devices

Integrated I/O

One floppy, Two serial (one header and one connector), and one parallel header
PS/2 KB/Mouse connectors
Total four USB connections (2 I/O panel, rear connectors and 2 USB headers)

System Management

Total six 3-pin fan headers with tachometer monitoring
Three fan headers with PWM control
2-pin Chassis Intrusion header
Temperature, voltage and fan monitoring

Integrated SATA Controller

Silicon Image SiI3114 SATA RAID
Supports SATA 1.0 Specification
Supports 4 channel SATA port for up to four SATA devices
Supports RAID 0, 1, 0+1
Connected to legacy 32-bit 33MHz PCI bus

Integrated PCI Graphics

ATI® Rage™ XL PCI graphics controller
8MB Frame Buffer of video memory

Integrated LAN Controllers

Two Broadcom® BCM5704C dual-channel Gigabit Ethernet controller
Two RJ-45 LAN connectors with LEDs
Connected to PCI-X Bridge A
Three Front Panel LED headers
One Intel® 82551QM10/100 Ethernet controller
Stacked USB 1.1 (two) ports and RJ45 LAN port on top

Intelligent Platform Management Interface Header

Tyan Server Management Daughter cards (optional); supports features listed below via IPMI header

QLogic™ Zircon Baseboard Management Controller (BMC) based on powerful ARM7 technology

Tailored for IPMI highest 1.5 Spec.

Supports KCS and BT styles

Flexible Windows or Linux Management Solution

Supports RMCP and SNMP protocols

Supports ASF standard and EMP

PC serial multi-master controllers and UARTs

Built-in IPMB connector

Remote power on/off and reset support (IPMI-over-LAN)

Integrated Dual Channel SCSI (manufacturing option)

Adaptec AIC7902W Dual-Channel U320 SCSI controller
Connects to PCI-X Bridge A
Adaptec® and Intel® Zero-Channel RAID ready

BIOS

AMI® BIOS 8.0 on 4Mbit LPC Flash ROM
Supports ACPI 1.0b & 2.0
PnP, DMI2.0, WfM2.0 Power Management
Power Management S1, S4 and S5 support

Form Factor

ATX footprint (12" x 9.8" 305 x 248 mm)

ATX12V/EPS12V (24pin + 8pin) power connectors

4-pin auxiliary power connector
Serial (one) and VGA (one) connectors

Stacked USB 1.1 (two) ports and RJ45 LAN port on top

Stacked PS/2 keyboard and mouse connectors

Two RJ-45 side-by-side LAN connectors with LEDs

Regulatory

FCC Class B (Declaration of Conformity)

European Community CE

(Declaration of Conformity)

Software Specifications

OS (Operating System) Support

Microsoft Windows NT 4 Service Pack 6A

Microsoft Windows 2000

Microsoft Windows XP

Microsoft Windows Server 2003

SuSE Server 8.0 for AMD-64

Red Hat 7.3, 8.0, and 9.0

Other distributions of Linux pending validation

TYAN reserves the right to add support or discontinue support for any OS with or without notice.

Chapter 2: Board Installation

Precaution: The Thunder K8S Pro supports EPS12V power supplies (24-pin/8-pin) and will not operate with any other types.

DO NOT USE ATX 2.x, ATX12V or ATXGES power supplies as they will damage the board and void your warranty.

How to install our products right... the first time

The first thing you should do is read this user's manual. It contains important information that will make configuration and setup much easier. Here are some precautions you should take when installing your motherboard:

- (1) Ground yourself properly before removing your motherboard from the antistatic bag. Unplug the power from your computer power supply and then touch a safely grounded object to release static charge (i.e. power supply case). For the safest conditions, TYAN recommends wearing a static safety wrist strap.
- (2) Hold the motherboard by its edges and do not touch the bottom of the board, or flex the board in any way.
- (3) Avoid touching the motherboard components, IC chips, connectors, memory modules, and leads.
- (4) Place the motherboard on a grounded antistatic surface or on the antistatic bag that the board was shipped in.
- (5) Inspect the board for damage.

The following pages include details on how to install your motherboard into your chassis, as well as installing the processor, memory, disk drives and cables.

NOTE DO NOT APPLY POWER TO THE BOARD IF IT HAS BEEN DAMAGED

2.00 – Board Image

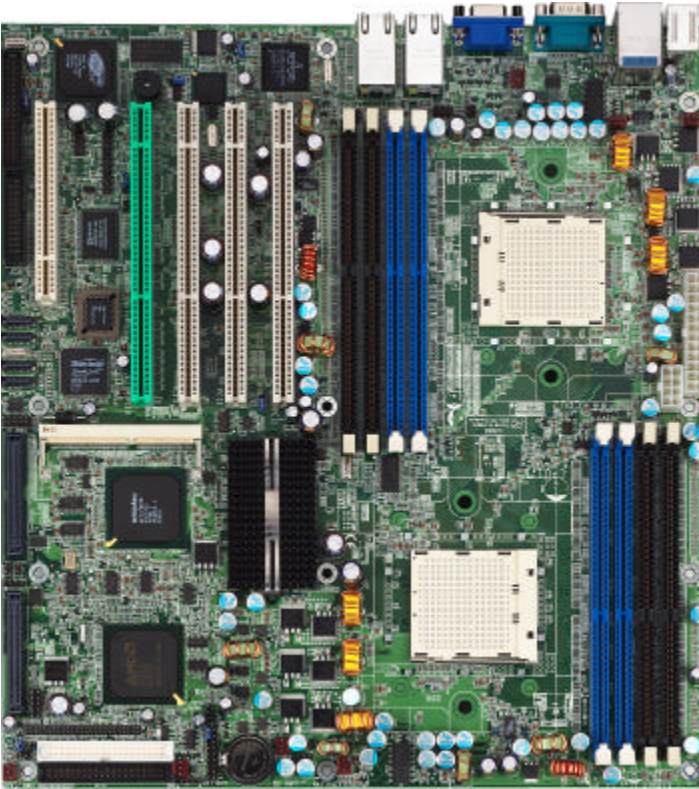

This picture is representative of the latest board revision available at the time of publishing. The board you receive may or may not look exactly like the above picture.

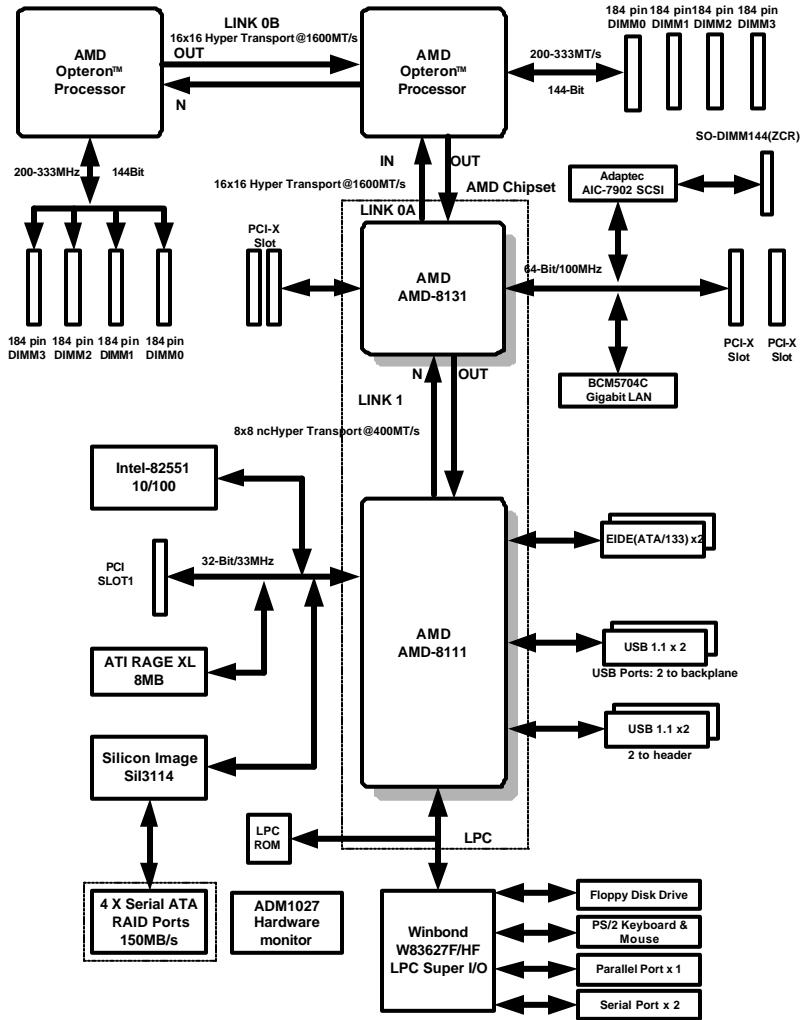

The following page includes details on the vital components of this motherboard.

Thunder K8S Pro S2882 Block Diagram





Jumper	Function	Settings
J1 / J2	Gigabit Ethernet LAN_2 & LAN_1 Front Panel LED Header	See Section 2.03 for pinout configuration
J6	Front Panel Connector	See Section 2.04 for pinout configuration
J8	Clear CMOS Jumper	Close Pin-1 and Pin-2 (Default) Normal mode Close Pin-2 and Pin-3 Clear CMOS mode
J11	SMBus_0 Connector	See section 2.06 for pinout configuration
J12	USB Connector header	For front or rear chassis mount USB connectors
J17	10/100 Ethernet LAN3 Front Panel LED Header	See Section 2.08 for pinout configuration
J19	Chassis Intrusion Connector	See Section 2.09 for pinout configuration
J22	ZCR Connector	
J23	COM2 Header	See Section 2.11 for pinout
J24 / J39	PCI-X Bridge B (PCI 1 & PCI 2) PCI-X Speed Select Jumper	133MHz: J24 & J39 open (Default) 100MHz: J24 close J39 open 66MHz: J24 & J39 close
J41	PCI-X Bridge A (PCI3 & PCI4) force PCI Mode Jumper	Open: PCI-X mode (Default) Close: PCI mode
J43	PCI-X Bridge A (PCI 3 & PCI 4 & SCSI7902 & BCM5704) PCI-X Speed Select Jumper	Open: up to PCI-X 100MHz (Default) Close: PCI-X 66MHz
J45	SMDC Connector	See Appendix II SMDC information
J46	Onboard VGA Enable/Disable Jumper	1-2 Close: Enable (Default) 2-3 Close: Disable
J52	Onboard Gigabit Ethernet Enable/Disable Jumper	Open: Disable Close: Enable (Default)
J60	Onboard 10/100 Ethernet Enable/Disable Jumper	1-2 Close: Enable (Default) 2-3 Close: Disable
P1_FAN (J5)	CPU_1 Fan Connector	With speed, MAX 2.0A
P2_FAN (J47)	CPU_2 Fan Connector	With speed, MAX 2.0A
FAN1 (J44)	Chassis Fan Connector	With speed control, MAX 3.0A
FAN2 (J48)	Chassis Fan Connector	With speed control, MAX 2.0A
FAN3 (J4)	Chassis Fan Connector	With speed control, MAX 3.0A
FAN4 (J9)	Chassis Fan Connector	With speed, MAX 2.0A
FAN5 (J3)	Chassis Fan Connector	With speed, MAX 2.0A

Jumper Legend

	OPEN - Jumper OFF	without jumper cover
	CLOSED - Jumper ON	with jumper cover

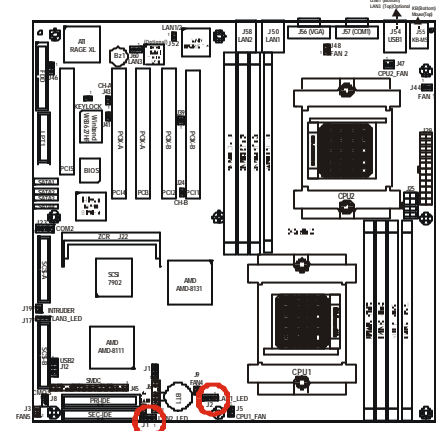
2.03 –Gigabit LAN_2 Front Panel LED Header (J1) and Gigabit LAN_1 Front Panel LED Header (J2)



			
Pin_4	Pin_3	Pin_2	Pin_1
Green -	Green +	Yellow -	Yellow +

Green LED solid= 10Mb link
Green LED flashing= 10Mb activity

Yellow LED solid= 100Mb link
Yellow LED flashing= 100Mb activity

Both LED Solid= Gigabit link
Both LED flashing= Gigabit activity

2.04 – Front Panel Connector (J6)

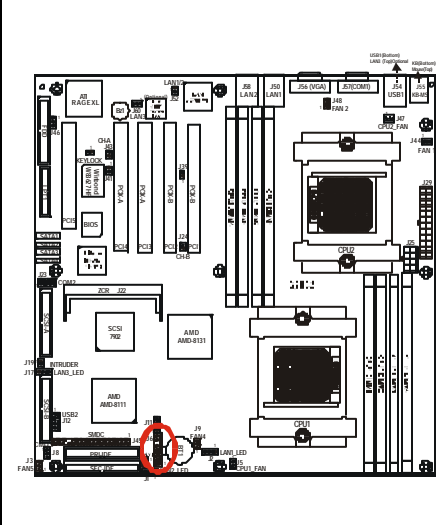

SPEAKER/BUZZER	18	17	INFRARED
POWER			RESET
PWR-LED			HD-LED

Function	PIN	PIN	Function
Speaker- / Buzzer-	18	17	NC
Buzzer+	16	15	IRTX
NONE	14	13	GND
Speaker+	12	11	IRRX
NC	10	9	+5V
GND	8	7	Reset SW+
PWR+	6	5	GND
Power LED -	4	3	HDD LED-
Power LED+	2	1	HDD LED+

2.05 – Clear CMOS Jumper (J8)

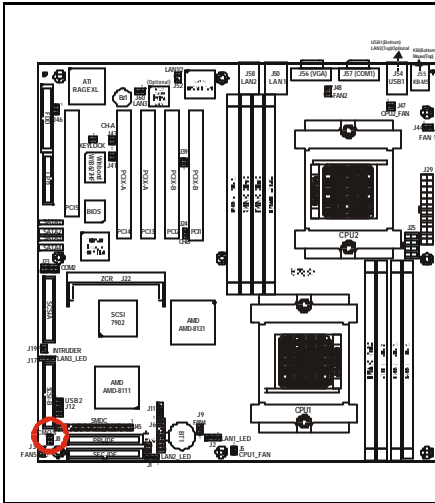

1		Default
3		
1		Clear
3		

You can reset the CMOS settings by using this jumper if you have forgotten your system/setup password or need to clear system BIOS setting.

- Power off system and **disconnect both power connectors from the motherboard**
- Use jumper cap to close Pin_2 and Pin_3 for several seconds to Clear CMOS
- Put jumper cap back to Pin_1 and Pin_2 (default setting)

Reconnect power & power on system

2.06 – SMBus_0 Connector (J11)

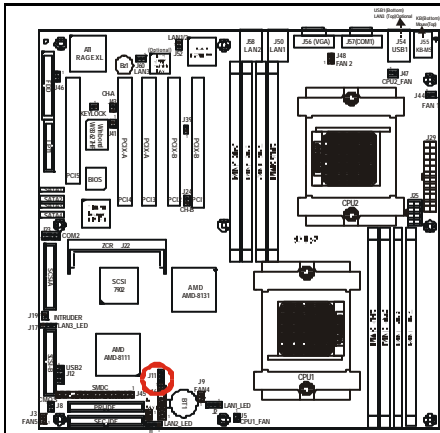

	Pin #	Signal Description
4	4	NC
	3	SMBUS_CLK
	2	GND
1	1	SMBUS_DATA

Use this connector to connect external SMBUS devices

2.07 – USB Connector Headers (J12)

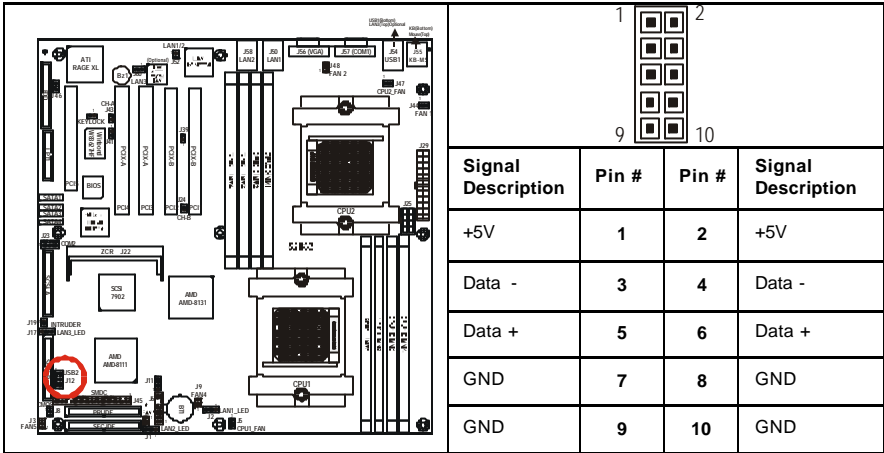

2.08 – 10/100 LAN Front Panel LED Header (J17)

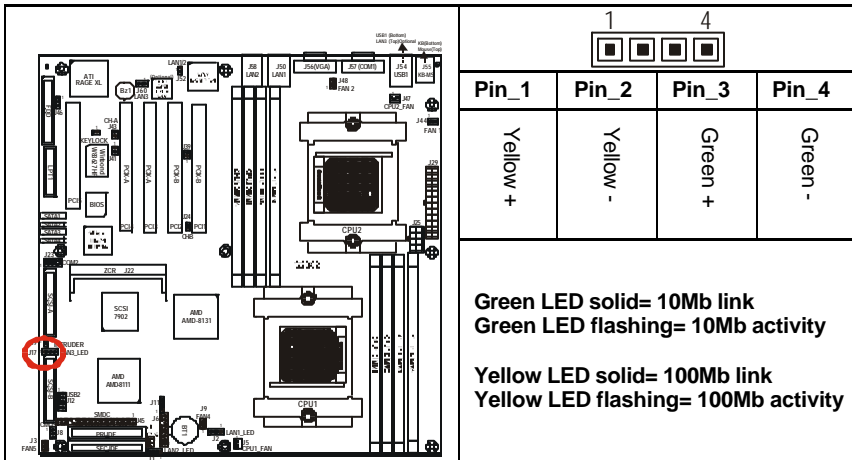

2.09 – Chassis Intrusion Connector (J19)

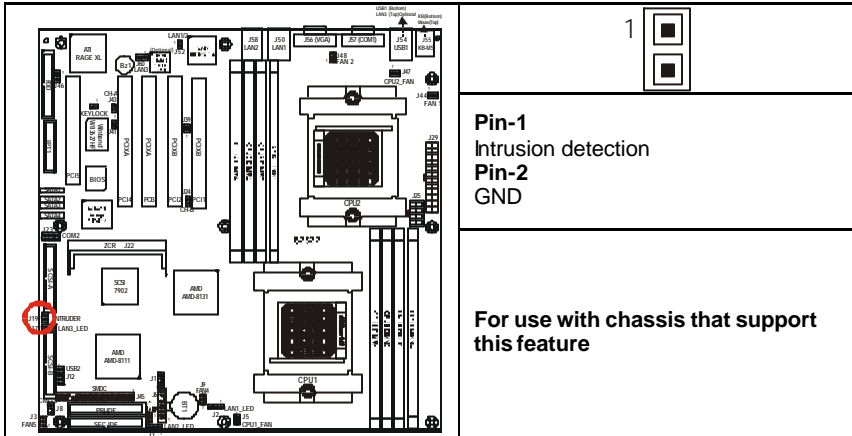

2.10 – ZCR Connector (J22)

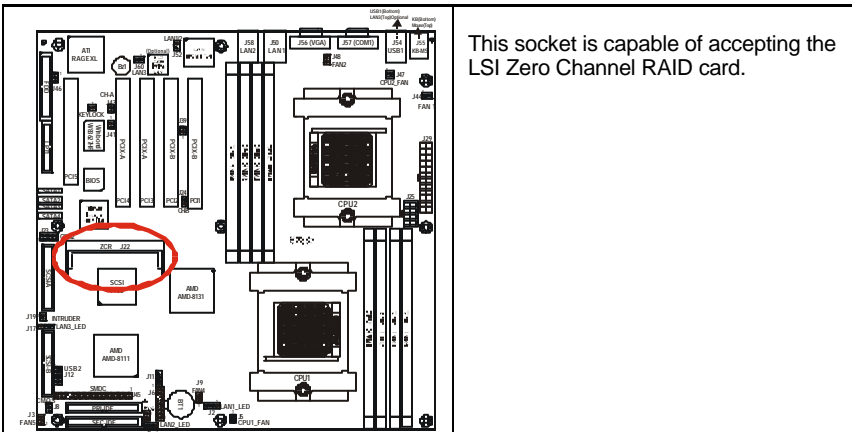



2.11 – COM2 Header (J23)

	Signal Description	Pin#	Pin#	Signal Description
	NC/KEY	10	9	GND (Ground)
	RI (Ring-Indicator)	8	7	DTR (Data-Terminal-Ready)
	CTS (Clear-to-Send)	6	5	TX (Transfer-Data)
	RTS (Request-to-Send)	4	3	RX (Receive-Data)
DSR (Data-Set-Ready)	2	1	DCD (Data Carrier Detect)	



2.12 – PCI-X Bridge B (PCI 1 & PCI 2) PCI-X Speed Select Jumper (J24 / J39)

	Speed			
	133MHz	J24 / J39		
	100MHz	J39	J24	
	66MHz		J24 / J39	
	Allows PCI-X Bridge B to operate at up to 133MHz (For use with one PCI-X 133 device)			
	Tyan recommends using PCI-X Slot 1 for 133MHz support			

2.13 – PCI-X Bridge A (PCI 3 & PCI 4) force PCI Mode Jumper (J41)

	<div style="text-align: center;">  </div> <p>OPEN (Default) Allows PCI 3 and PCI 4 to operate in PCI-X Mode</p> <hr/> <div style="text-align: center;">  </div> <p>CLOSED To force PCI 3 and PCI 4 to operate in PCI compatible mode. Close this jumper if the card you are using does not support PCI-X.</p>
--	---

2.14 – PCI-X Bridge A (PCI 3 & PCI 4 & SCSI7902 & BCM5704) PCI-X Speed Select Jumper (J43)

	<div style="text-align: center;">  </div> <p>OPEN (Default) Allows PCI-X Bridge A (PCI 3 & PCI 4 & SCSI7902 & BCM5704) to operate at up to 100MHz</p> <hr/> <div style="text-align: center;">  </div> <p>CLOSED Sets PCI-X Bridge A (PCI 3 & PCI 4 & SCSI7902 & BCM5704) to operate at a maximum 66MHz</p> <p>Note: Due to the PCI-X specifications it will be necessary to set this bus to 66MHz if a 133/100MHz PCI-X card is added to this bus.</p>
--	--

2.15 – SMDC Connector (J45)

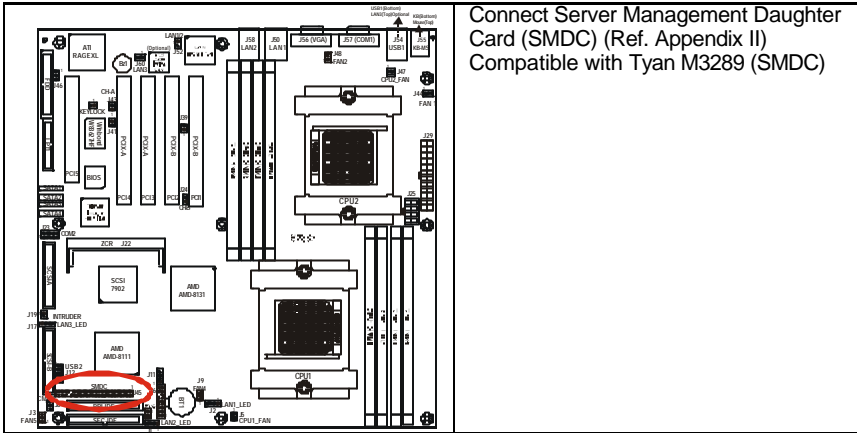

2.16 – Onboard VGA Enable/Disable Jumper (J46)

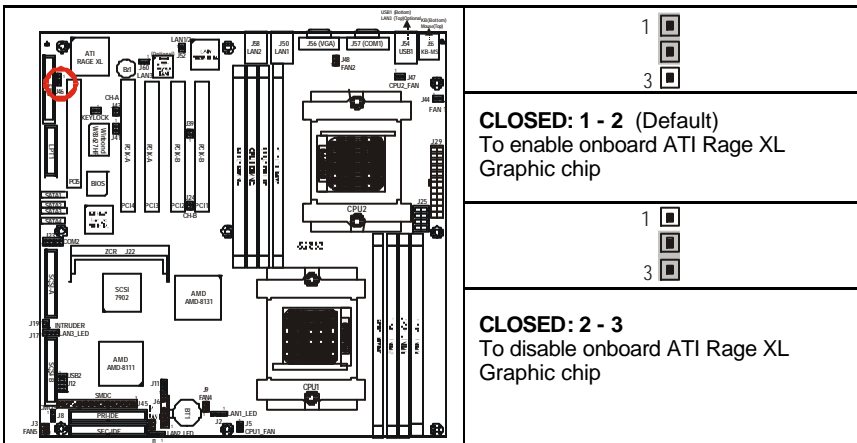

2.17 – Onboard Gigabit Ethernet Enable/Disable Jumper (J52)

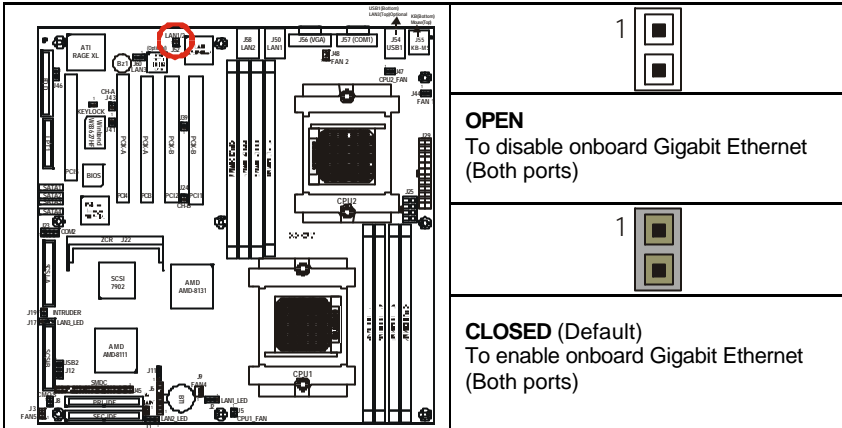

2.18 – Onboard 10/100 Ethernet Enable/Disable Jumper (J60)

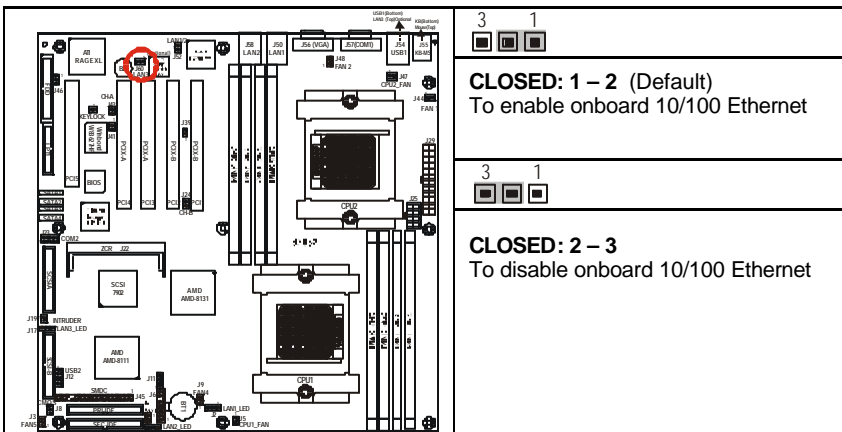

2.19 – CPU_1 Fan Connector (P1_FAN) (J5)

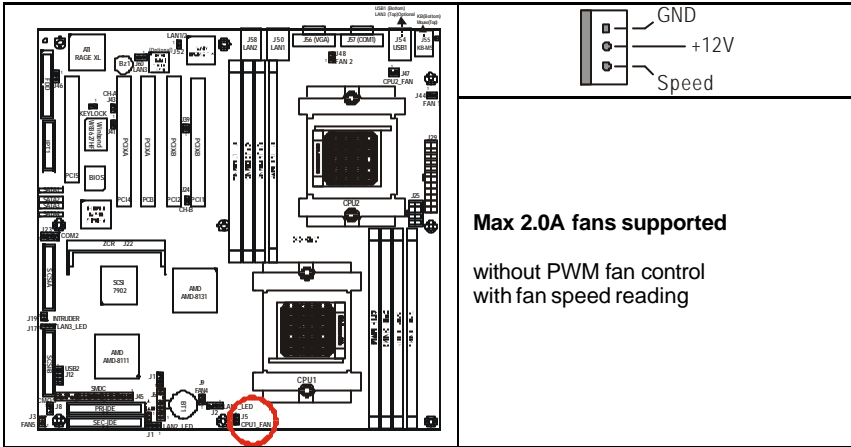

2.20 – CPU_2 Fan Connector (P2_FAN) (J47)

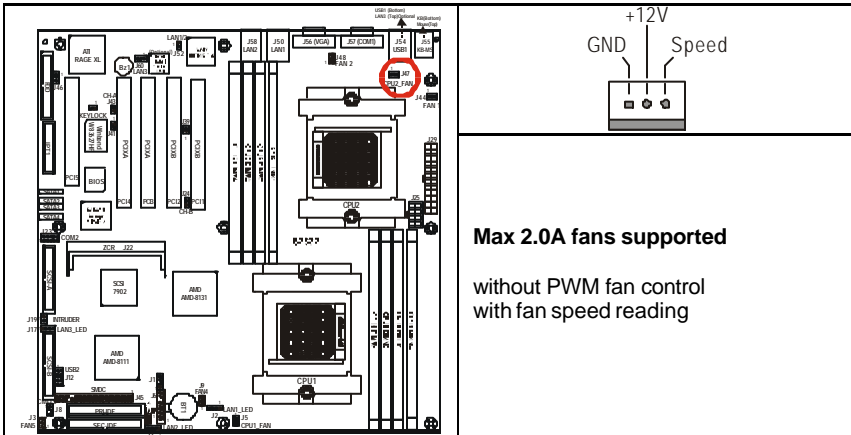

2.21 – FAN 1 Chassis Fan Connector (J44)

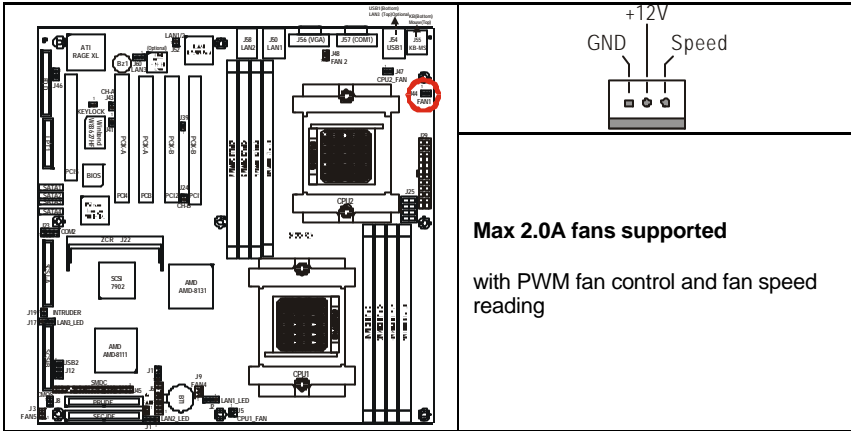

Max 2.0A fans supported

with PWM fan control and fan speed reading

2.22 – FAN 2 Chassis Fan Connector (J48)

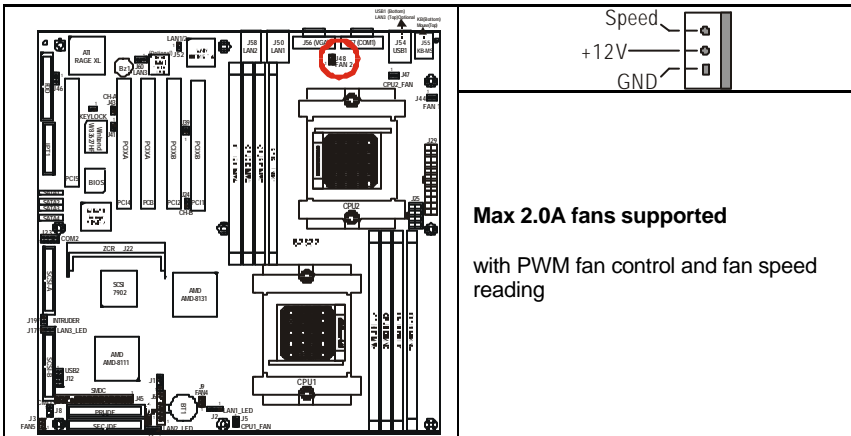

Max 2.0A fans supported

with PWM fan control and fan speed reading

2.23 – FAN3 Chassis Fan Connector (J4)

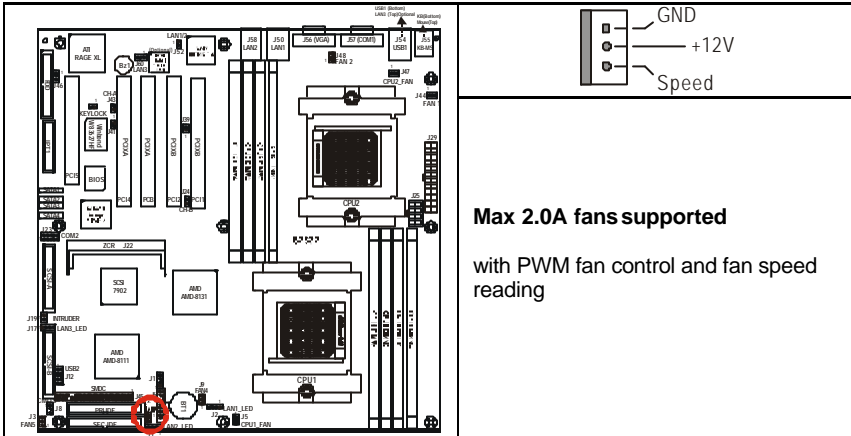

2.24 – FAN 4 Chassis Fan Connector (J9)

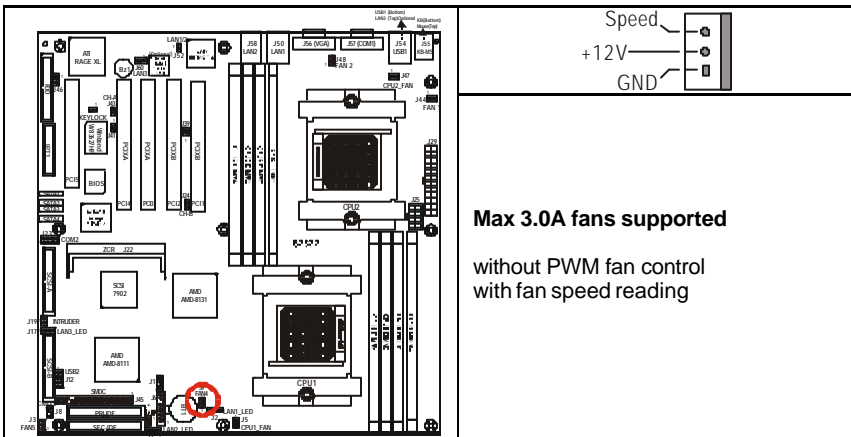

2.25 – FAN 5 Chassis Fan Connector (J3)

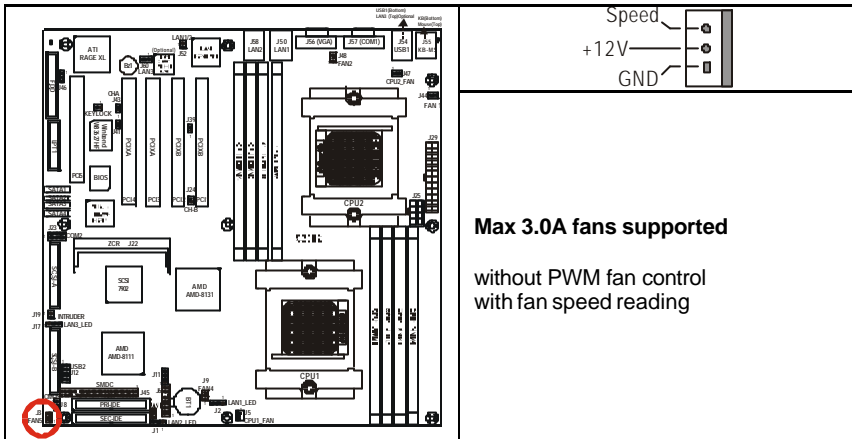

2.26 – OEM Reserved Connectors and Jumpers

These connectors and jumpers which are not listed are reserved for OEM use only.

2.27 – Installing the Processor(s)

Your brand new Thunder K8S Pro supports the latest 64-bit processor technologies from AMD. Only AMD Opteron™ processor 200 series are certified and supported with this motherboard.

Check our website for latest processor support. <http://www.tyan.com>

NOTE

If using a single processor, it MUST be installed in socket CPU1.
When using a single processor only CPU1 memory banks are addressable.

TYAN is not liable for damage as a result of operating an unsupported configuration.

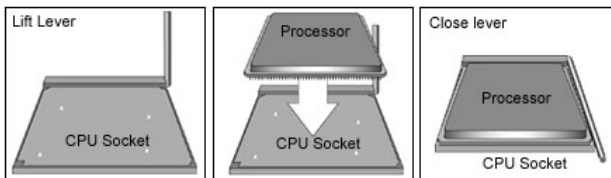

The diagram is provided as a visual guide to help you install socket processors and may not be an exact representation of the processors you have.

Lift the lever on the socket until it is approximately 90° or as far back as possible to the socket.

Align the processor with the socket. There are keyed pins underneath the processor to ensure that the processor is installed correctly.

Seat the processor firmly into the socket by gently pressing down until the processor sits flush with the socket.

Place the socket lever back down until it locks into place.

Your processor is installed.

Repeat these steps for the second processor if you are using two processors.

Take care when installing processors as they have very fragile connector pins below the processor and can bend and break if inserted improperly.

2.28— Heatsink Retention Frame Installation

After you are done installing the processor(s), you should proceed to installing the retention frame and heatsink. The CPU heatsink will ensure that the processors do not overheat and continue to operate at maximum performance for as long as you own them. Overheated processors are also dangerous to the health of the motherboard.

The backplate assembly prevents excessive motherboard flexing in the area near the processor and provides a base for the installation of the heatsink retention bracket and heatsink.

Because there are many different types of heatsinks available from many different manufacturers, a lot of them have their own method of installation. For the safest method of installation and information on choosing the appropriate heatsink, use heatsinks validated by AMD. Please refer to AMD's website at www.amd.com.

The following diagram will illustrate how to install the most common CPU back plates:

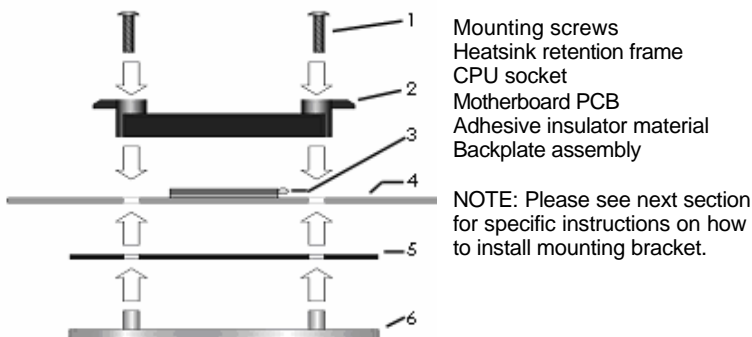

2.29 – Thermal Interface Material

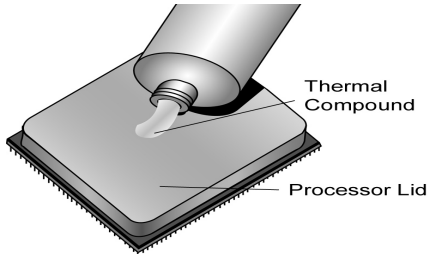
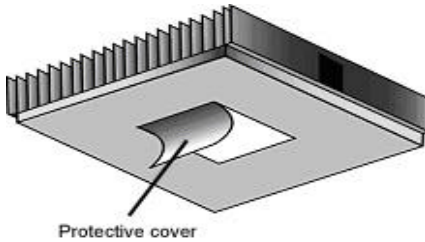

There are two types of thermal interface materials designed for use with the AMD Opteron processor.

The most common material comes as a small pad attached to the heatsink at the time of purchase. There should be a protective cover over the material. Take care not to touch this material.

Simply remove the protective cover and place the heatsink on the processor.

The second type of interface material is usually packaged separately. It is commonly referred to as 'thermal compound'. Simply apply a thin layer on to the CPU lid (applying too much will actually reduce the cooling).

NOTE

Always check with the manufacturer of the heatsink & processor to ensure the Thermal Interface material is compatible with the processor & meets the manufacturer's warranty requirements

2.30 – Heatsink Installation Procedures

Type A: CAM LEVER (TYPE) INSTALLATION

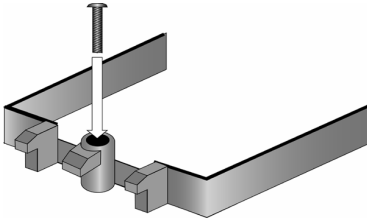

1. After placing backplate and interface material under motherboard place heatsink retention frame on top of motherboard. Align plastic retention bracket screw hole with CPU back-plate standoffs. Tighten screws to secure plastic retention bracket. Repeat for on other side. **DO NOT OVER TIGHTEN.**

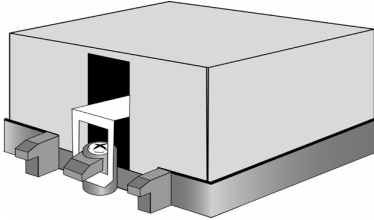

2. After tightening screws secure metal clip to plastic retention bracket center tab. Repeat for on other side of heatsink.

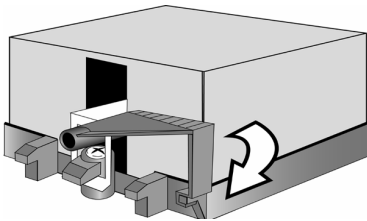

3. After securing metal clip to plastic retention bracket center tab, push down on plastic clip to lock plastic clip to side tab.

Type B: SCREW RETENTION TYPE HEATSINK

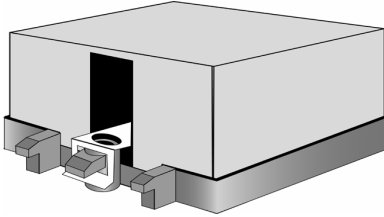

1. After placing CPU back-plate and adhesive interface material under motherboard, place heatsink retention frame on top of motherboard. Align heatsink retention frame screw hole with backplate assembly standoffs. Place heatsink inside plastic retention bracket. Place metal clip over retention frame tab. Repeat for other side.

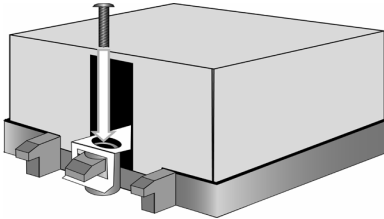

2. Insert screw through metal clip. **BE SURE METAL CLIP IS LOCKED ONTO RETENTION FRAME TAB.**

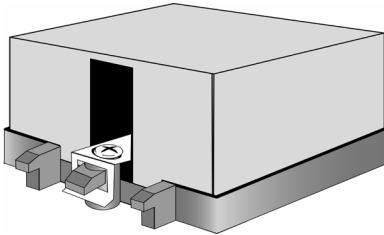

3. Tighten screw through metal clip. Repeat on other side. **DO NOT OVER TIGHTEN.**

2.31 -- Finishing Installing the Heatsink

After you have finished installing the heatsink onto the processor and socket, attach the end wire of the fan (which should already be attached to the heatsink) to the motherboard. The following diagram illustrates how to connect fans onto the motherboard.

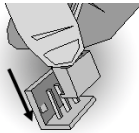

Once you have finished installing all the fans you can connect your drives (hard drives, CD-ROM drives, etc.) to your motherboard.

2.32 – Tips on Installing Motherboard in Chassis

Before installing your motherboard, make sure your chassis has the necessary motherboard support studs installed. These studs are usually metal and are gold in color. Usually, the chassis manufacturer will pre-install the support studs. If you are unsure of stud placement, simply lay the motherboard inside the chassis and align the screw holes of the motherboard to the studs inside the case. If there are any studs missing, you will know right away since the motherboard will not be able to be securely installed.

Some chassis' include plastic studs instead of metal. Although the plastic studs are usable, TYAN recommends using metal studs with screws that will fasten the motherboard more securely in place.

Below is a chart detailing what the most common motherboard studs look like and how they should be installed.

Mounting the Motherboard

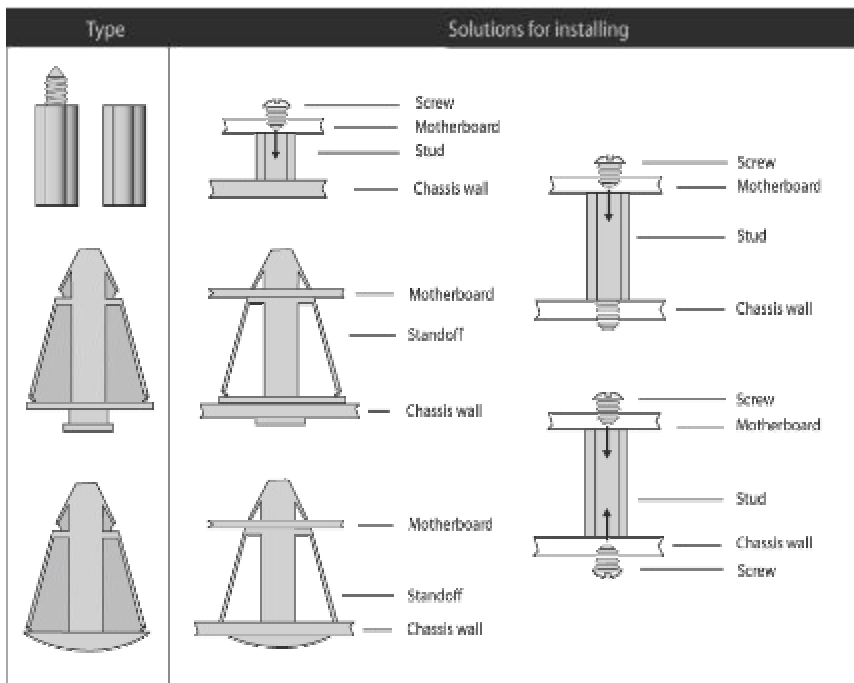

2.33 – Installing the Memory

Before attempting to install any memory, make sure that the memory you have is compatible with the motherboard as well as the processor.

The following diagram shows common types of DDR SDRAM modules:

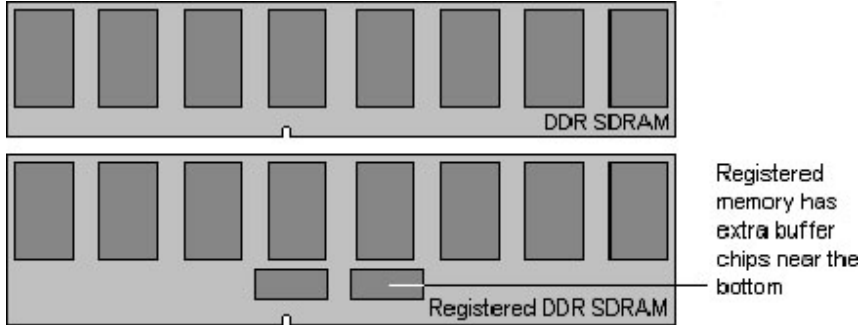

Here are a few key points to note before installing memory into your Thunder K8S Pro:

- Always install memory beginning with DIMM1
- AMD Opteron™ processors support 64bit (non-interleaved) or 128bit (interleaved) memory configurations
- At least ONE Registered DDR SDRAM module must be installed for the system to turn on and POST (power on self test)
- 128MB, 256MB, 512MB, 1GB, and 2GB* Registered PC2700/PC2100/PC1600 DDR SDRAM memory modules are supported
- All installed memory will be automatically detected
- The Thunder K8S Pro supports up to 8GB.*

* Not validated at the time of print; subject to change.

This chart outlines the rules for populating memory

(Note: X indicates a populated DIMM Slot)

DIMM Slot	128Bit support																	
CPU1 DIMM1	x				x	x	x							x	x	x		x
CPU1 DIMM2	x				x	x	x							x	x	x		x
CPU1 DIMM3		x			x			x	x					x	x		x	x
CPU1 DIMM4		x			x			x	x					x	x		x	x
CPU2 DIMM1			x			x		x		x	x			x	x		x	x
CPU2 DIMM2			x			x		x		x	x			x	x		x	x
CPU2 DIMM3				x			x		x	x				x	x	x	x	x
CPU2 DIMM4				x			x		x	x				x	x	x	x	x

DIMM Slot	64-Bit Support												
CPU1 DIMM1	X				X	X	X				X		X
CPU1 DIMM3		X			X			X	X		X	X	X
CPU2 DIMM1			X			X		X		X	X	X	X
CPU2 DIMM3				X			X		X	X		X	X

Memory Installation Procedure

When you install the memory modules, make sure the module aligns properly with the memory slot. The modules are keyed to ensure that it is inserted only one way. The method of installing memory modules are detailed by the following diagrams.

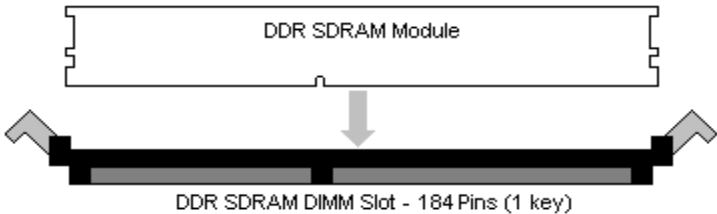

Once the memory modules are firmly seated in the slot, two latches on either side will close and secure the module into the slot. Sometimes you may need to close the latches yourself.

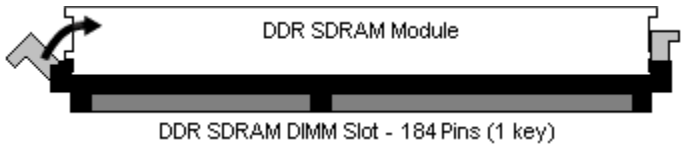

To remove the memory module, simply push the latches outwards until the memory module pops up. Then remove the module.

NOTE

YOU MUST ALWAYS unplug the power connector from the motherboard before performing system hardware changes. Otherwise you may damage the board and/or expansion device.

2.34 – Attaching Drive Cables

Attaching the IDE drive cable is simple. These cables are “keyed” to only allow them to be connected in the correct manner. TYAN motherboards have two on-board IDE channels, each supporting two drives. **The black connector designates the Primary channel, while the white connector designates the Secondary channel.**

Attaching IDE cables to the IDE connectors is illustrated below:

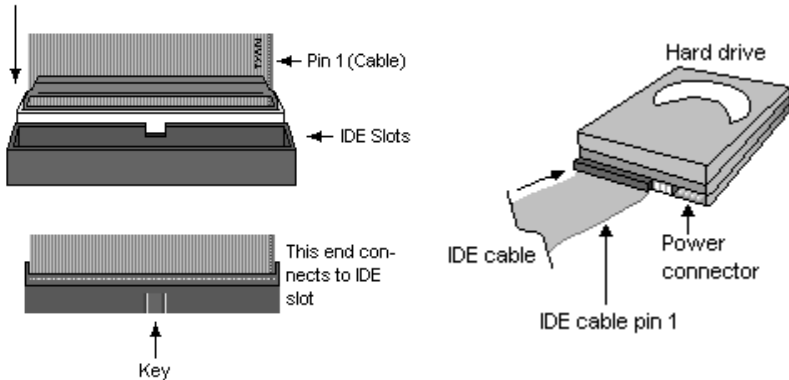

Simply plug in the BLUE END of the IDE cable into the motherboard IDE connector, and the other end(s) into the drive(s). Each standard IDE cable has three connectors, two of which are closer together. The BLUE connector that is furthest away from the other two is the end that connects to the motherboard. The other two connectors are used to connect to drives.

Note: Always remember to properly set the drive jumpers. If only using one device on a channel, it must be set as Master for the BIOS to detect it.

TIP: Pin 1 on the IDE cable (usually designated by a colored wire) faces the drive's power connector.

The Thunder K8S Pro is also equipped with 4 Serial ATA (SATA) channels. Connections for these drives are also very simple.

There is no need to set Master/Slave jumpers on SATA drives.

Tyan has supplied two SATA cables and one SATA power adapter. If you are in need of other cables or power adapters please contact your place of purchase.

The following pictures illustrate how to connect an SATA drive

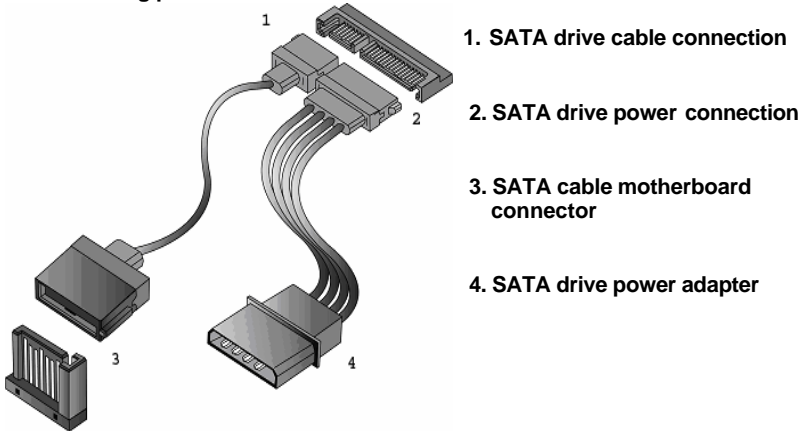

Floppy Drives

Attaching floppy diskette drives are done in a similar manner to hard drives. See the picture below for an example of a floppy cable. Most of the current floppy drives on the market require that the cable be installed with the colored stripe positioned next to the power connector. In most cases, there will be a key pin on the cable which will force a proper connection of the cable.

Twist at the end of the ribbon cable

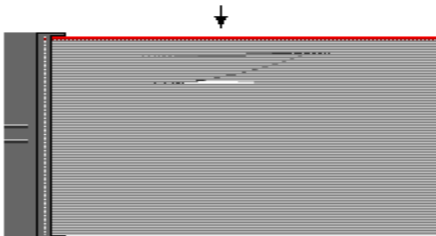

Attach first floppy drive (drive **A:**) to the end of the cable with the twist in it. Drive **B:** is usually connected to the next possible connector on the cable (the second or third connector after you install Drive **A:**).

2.35 – Installing Add-In Cards

Before installing add-in cards, it's helpful to know if they are fully compatible with your motherboard. For this reason, we've provided the diagrams below, showing the most common slots that may appear on your motherboard. Not all of the slots shown will necessarily appear on your motherboard.

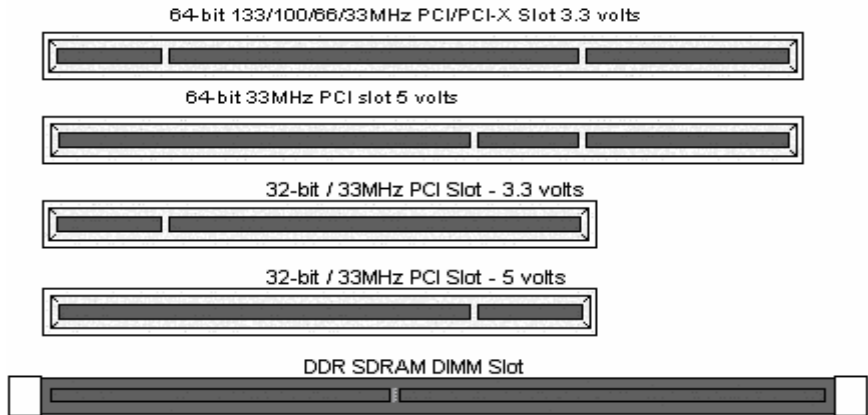





Simply find the appropriate slot for your add-in card and insert the card firmly. Do not force any add-in cards into any slots if they do not seat in place. It is better to try another slot or return the faulty card rather than damaging both the motherboard and the add-in card.

NOTE

YOU MUST ALWAYS unplug the power connector from the motherboard before performing system hardware changes. Otherwise you may damage the board and/or expansion device.

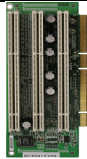
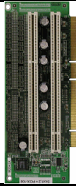
2.36 – PCI Riser Cards Supported on S2882 K8S

				
Model Number	M2037	M2043	M2043X	M2044
What speeds can support	ALL SPEEDS	66MHz 33MHz	100MHz 66MHz 33MHz	133MHz 100MHz 66MHz
Form Factor	1U	2U	2U	2U
What kind of Gold Finger	3.3V and 5V	3.3V and 5V	3.3V and 5V	3.3V and 5V
How many slots	1	3	2	3
What kinds of slots	5V	3.3V	3.3V	3.3V
UPC Code	635872-007255	635872-006906	635872-007095	635872-008368

2.37 – Connecting External Devices

Connecting external devices to the motherboard is an easy task. The following diagrams will detail the rear port stack for this S2882 motherboard:

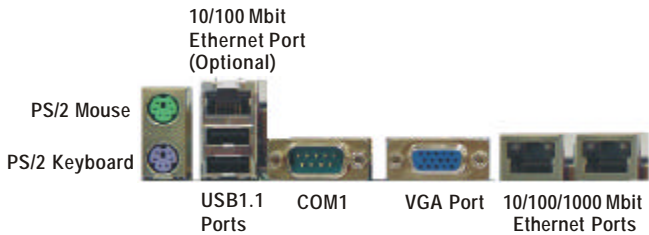

LAN Link/Activity LED Scheme		
Speed	Link LED (left side)	Activity LED (right side)
10Mbps	Green (Blink)	Off
100Mbps	Off	Yellow (Blink)



LAN Link/Activity LED Scheme		
Speed	Link LED (left side)	Activity LED (right side)
10Mbps	Green (Blink)	Off
100Mbps	Off	Yellow (Blink)
1000Mbps	Green (Blink)	Yellow (Blink)

2.38 – Installing the Power Supply

There are two power connectors on your Thunder K8S Pro S2882. The Thunder K8S Pro S2882 requires that you have an EPS12V power supply that has a 24-pin and an 8-pin power connector. Please be aware that ATX 2.x, ATX12V and ATXGES power supplies are not compatible with the board and can damage the motherboard and/or CPU(s).

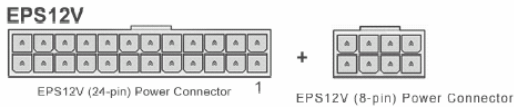

Disconnect power supply from electrical outlet

1. Connect the EP12V 8-pin power connector
2. Connect the EP12V 24-pin power connector
3. Connect power cable to power supply to power outlet

Make sure you have connected both connectors before attempting to apply power to the board.

NOTE

YOU MUST unplug the power supply before plugging the power cables to motherboard connectors.

2.39 – Finishing Up

Congratulations on making it this far! You're finished setting up the hardware aspect of your computer. Before closing up your chassis, make sure that all cables and wires are connected properly, especially IDE cables and most importantly, jumpers. You may have difficulty powering on your system if the motherboard jumpers are not set correctly.

In the rare circumstance that you have experienced difficulty, you can find help by asking your vendor for assistance. If they are not available for assistance, please find setup information and documentation online at our website or by **calling your vendor's support line**.

Chapter 3: BIOS

3.00 – BIOS Setup Utility

With the BIOS setup utility, you can modify BIOS settings and control the special features of your computer. The setup utility uses a number of menus for making changes and turning the special features on or off.

NOTE

All menus are based on a typical system. The actual menus displayed on your screen may be different and depend on the hardware and features installed in your computer.

To start the BIOS setup utility:

- Turn on or reboot your system
- Press during POST (F4 on remote console) to start BIOS setup utility

BIOS Setup Utility	
Main	Advanced PCI/PnP Boot Security Chipset Power Exit
System Overview	Use [ENTER], [TAB] or [SHIFT_TAB] to select a field
AMIBIOS Version : 08.00.xx Build Date : 7/17/2003 ID : 0AAAA000	Use [+] or [-] to configure system time.
Processor Type : AMD Opteron(tm) Model xxx Speed : xxxx MHz Count : x	?? Select Screen
System Memory Size : xxxx MB	?? Select Item
System Time : [12:59:59]	+/- Change Option
System Date : [07/17/2003]	F1 General Help
	F10 Save and Exit
	ESC Exit

To select an item

Use the left/right (← →) arrow keys to make a selection

To display a sub-menu (A pointer “▶” marks all sub menus)

Use the arrow keys to move the cursor to the sub menu you want. Then press <Enter>.

3.01 – BIOS Menu Bar

The menu bar at the top of the windows lists these selections:

Main	To configure basic system setups
Advanced	To configure the advanced chipset features
PCI/PnP	To configure legacy Plug & Play or PCI settings
Boot	To configure system boot order
Security	To configure user and supervisor passwords
Chipset	To configure chipset management features
Power	To configure power management features
Exit	To exit setup utility

NOTE

Options written in **bold type** represent the BIOS setup default

3.02 – BIOS Legend Bar

The chart describes the legend keys and their alternates:

Key	Function
<F1> or <Alt-H>	General help window
<ESC>	Exit current menu
← → arrow keys	Select a different menu
↑ or ↓ arrow keys	Move cursor up/down
<Tab> or <Shift-Tab>	Cycle cursor up/down
<Home> or <End>	Move cursor to top/bottom of the window
<PgUp> or <Pg Dn>	Move cursor to next/previous page
<F5> or <->	Select the previous value/setting of the field
<F6> or <+> or <Space>	Select the next value/setting of the field
<F8>	Load Fail Safe default configuration values of the menu
<F9>	Load the Optimal default configuration values of the menu
<F10>	Save and exit
<Enter>	Execute command or select submenu

3.03 – BIOS Main Menu

The Main BIOS Menu is the first screen that you can navigate. The Main BIOS setup menu screen has two main frames. The left frame displays all the options that can be configured. "Grayed-out" options cannot be configured, options in blue can be changed.

The right frame displays the key legend. Above the key legend is an area reserved for a text message. When an option is selected in the left frame, it is highlighted in white. Often, a text message will accompany it.

BIOS Setup Utility							
Main	Advanced	PCI/PnP	Boot	Security	Chipset	Power	Exit
System Overview					Use [ENTER], [TAB] or [SHIFT_TAB] to select a field		
AMIBIOS Version : 08.00.xx Build Date : 7/17/2003 ID : 0AAAA000					Use [+] or [-] to configure system time.		
Processor Type : AMD Opteron(tm) Model xxxx Speed : xxxx MHz Count : x					?? Select Screen		
System Memory Size : xxxx MB					?? Select Item		
System Time [12:59:59] System Date [07/17/2003]					Enter Go to Sub Screen		
					F1 General Help		
					F10 Save and Exit		
					ESC Exit		

Feature	Option	Description
Main		
System Time	HH : MM : SS	Set the system time
System Date	MM : DD : YYYY	Set the system date

3.04 – BIOS Advanced Menu

You can select any of the items in the left frame of the screen, such as Super I/O Configuration, to go to the sub menu for that item. You can display an Advanced BIOS Setup option by highlighting it using the <Arrow> keys. All Advanced BIOS Setup options are described in this section. The Advanced BIOS Setup screen is shown below. The sub menus are described on the following pages.

BIOS Setup Utility							
Main	Advanced	PCI/PnP	Boot	Security	Chipset	Power	Exit
Advanced Settings					Use [ENTER], [TAB] or [SHIFT_TAB] to select a field		
WARNING: Setting wrong values in below sections may cause system to malfunction. <ul style="list-style-type: none"> ▶ IDE Configuration ▶ Floppy Configuration ▶ Super I/O Configuration ▶ Hardware Health Configuration ▶ ACPI Configuration ▶ Event Log Configuration ▶ Hyper Transport Configuration ▶ Device & PCI Slots Configuration ▶ Remote Access Configuration ▶ USB Configuration 					Use [+] or [-] to configure system time.		
					?? Select Screen		
					?? Select Item		
					Enter Go to Sub Screen		
					F1 General Help		
					F10 Save and Exit		
					ESC Exit		

Feature	Option	Description
Advanced Settings		
IDE Configuration	Menu Item	Configures devices connected to AMD8111 IDE controller
Floppy Configuration	Menu Item	Configures devices connected to the floppy controller
Super I/O Configuration	Menu Item	Configures devices connected to the Super I/O Configuration
Hardware Health Configuration	Menu Item	Configures & views Hardware Monitor
ACPI Configuration	Menu Item	Section for Advanced ACPI Configuration
Event Log Configuration	Menu Item	Views & controls Event Log
Hyper Transport Configuration	Menu Item	Configure HT links
Device & PCI Slots Configuration	Menu Item	Allows control of integrated devices & cards plugged into PCI slots
Remote Access Configuration	Menu Item	Configures Console Redirect
USB Configuration	Menu Item	Configures USB controller & legacy device support

3.04.1 – IDE Configuration Sub-Menu

You can use this screen to select options for the IDE Configuration Settings. Use the up and down <Arrow> keys to select an item. Use the <Plus> and <Minus> keys to change the value of the selected option.

BIOS Setup Utility		
Main	Advanced	PCI/PnP Boot Security Chipset Power Exit
IDE Configuration		Use [ENTER], [TAB] or [SHIFT_TAB] to select a field
Onboard PCI IDE Controller	[Both]	Use [+] or [-] to configure system time.
▶ Primary IDE Master	[xxxx]	?? Select Screen
▶ Primary IDE Slave	[xxxx]	?? Select Item
▶ Secondary IDE Master	[xxxx]	+/- Change Option
▶ Secondary IDE Slave	[xxxx]	F1 General Help
Hard Disk Write Protect	[Disable]	F10 Save and Exit
IDE Detect Time Out (Sec)	[xx]	ESC Exit

Feature	Option	Description
IDE Configuration		
Onboard PCI IDE Controller	Both	This setting determines whether the AMD 8111 primary and secondary IDE channels are activated.
	Primary	
	Secondary	
	Disabled	
Primary/Secondary Master Primary/Secondary Slave	Auto	Auto - To determine the IDE drive type by system BIOS User - To set IDE drive type by user ATAPI Removable – Read/write media (e.g. IDE ZIP) CD-ROM - Readable CD-ROM drive
	User	
	ATAPI Removable	
	CD-ROM	
	None	
Hard Disk Write Protect	Disabled	This option protects the first sector of the IDE HDD from being written.
	Enabled	
IDE Detect Time Out (Sec)	35 ~ 0	Configure the time (in Seconds) before the BIOS times out on detecting an IDE Device.

3.04.2 – Floppy Configuration Sub-Menu

You can use this screen to specify options for the Floppy Configuration Settings. Use the up and down <Arrow> keys to select an item. Use the <Plus> and <Minus> keys to change the value of the selected option. The settings are described on the following pages.

BIOS Setup Utility	
Main	Advanced PCI/PnP Boot Security Chipset Power Exit
Floppy Configuration	Use [ENTER], [TAB] or [SHIFT_TAB] to select a field
Floppy A [1.44 MB 3 1/2"]	Use [+] or [-] to configure system time. ?? Select Screen ?? Select Item +/- Change Option F1 General Help F10 Save and Exit ESC Exit
Floppy B [Disabled]	

Feature	Option	Description
Floppy Configuration		
Floppy A	Disabled	This setting selects the type of the floppy disk drive installed in system.
	360 KB 5 1/4"	
	1.2 MB 5 1/4"	
	720 KB 3 1/2"	
	1.44 MB 3 1/2"	
Floppy B	Disabled	This setting selects the type of the floppy disk drive installed in system.
	360 KB 5 1/4"	
	1.2 MB 5 1/4"	
	720 KB 3 1/2"	
	1.44 MB 3 1/2"	
	2.88 MB 3 1/2"	

3.04.3 – Super I/O Configuration Sub-Menu

You can use this screen to select options for the Super I/O settings. Use the up and down arrow (↑/↓) keys to select an item. Use the Plus and Minus (+/-) keys to change the value of the selected option

BIOS Setup Utility							
Main	Advanced	PCI/PnP	Boot	Security	Chipset	Power	Exit
Configure Win627 Super IO Chipset						Use [ENTER], [TAB] or [SHIFT_TAB] to select a field	
Onboard Floppy Controller			[Enabled]		Use [+] or [-] to configure system time.		
Serial Port1 Address			[3F8/IRQ4]		?? Select Screen		
Serial Port2 Address			[2F8/IRQ3]		?? Select Item		
Serial Port2 Mode			[Normal]		+/- Change Option		
Parallel Port Address			[378]		F1 General Help		
Parallel Port Mode			[Normal]		F10 Save and Exit		
Parallel Port IRQ			[IRQ7]		ESC Exit		

Feature	Option	Description
Configure Win627 Super IO Chipset		
Onboard Floppy Controller	Enabled	Enables or Disables the Onboard Floppy Controller.
	Disabled	
Serial Port1 Address	3F8/IRQ4	Sets the serial port 1 (COM1) base I/O address and an interrupt number Disabled –turn off port
	3E8/IRQ4	
	2E8/IRQ3	
	Disabled	
Serial Port2 Address	2F8/IRQ3	Sets the serial port 2 (COM2) base I/O address and an interrupt number Disabled –turn off port
	3E8/IRQ4	
	2E8/IRQ3	
	Disabled	
Serial Port2 Mode	Normal	Allows BIOS to Select Mode for Serial Port2.
	IrDA	
	ASK IR	
Parallel Port Address	378	Assigns the Parallel Port base I/O address. Disabled –turn off port
	278	
	3BC	
	Disabled	
Parallel Port Mode	Bi-Directional	Configures Parallel port mode. Bi-Directional= send & receive data Normal= can send data EPP= Enhanced Parallel Port ECP=Extended Capability port
	Normal	
	EPP	
	ECP	
Parallel Port Interrupt	IRQ 7	Assigns IRQ to parallel port.
	IRQ 5	

Parallel Port DMA Channel	0~3	Assigns DMA channel for port.
---------------------------	-----	-------------------------------

3.04.4 – Hardware Health Event Monitoring Sub-Menu

You can use this screen to view the Hardware Health Configuration Settings. Use the up and down arrow (↑/↓) keys to select an item. Use the Plus and Minus (+/-) keys to change the value of the selected option. The settings are described on the following pages.

BIOS Setup Utility		
Main	Advanced	PCI/PnP Boot Security Chipset Power Exit
Hardware Health Event Monitoring		Use [ENTER], [TAB] or [SHIFT_TAB] to select a field
CPU2 Ambient Temperature	:xx C/ xxx F	Use [+] or [-] to configure system time.
DIMM 2.5V VRM Temperature	:xx C/ xxx F	
CPU VRM Temperature	:xx C/ xxx F	
CPU1 Temperature	:xx C/ xxx F	
CPU2 Temperature	:xx C/ xxx F	
System Temperature	:xx C/ xxx F	
CPU1 Fan Speed	:xxxx RPM	
CPU2 Fan Speed	:xxxx RPM	
FAN1 Speed	:xxxx RPM	?? Select Screen
FAN2 Speed	:xxxx RPM	?? Select Item
FAN3 Speed	:xxxx RPM	+/- Change Option
FAN4 Speed	:xxxx RPM	Tab Select Field
FAN5 Speed	:xxxx RPM	F1 General Help
▶ Mainboard Voltages Report		F10 Save and Exit
Auto FAN 1, 2, 3 Speed Control	[Disabled]	ESC Exit
Chassis Intrusion Detect	[Disabled]	

Feature	Option	Description
Hardware Health Event Monitoring		
CPU2 Ambient Temperature		Displays CPU Ambient & VRM Temperatures.
DIMM 2.5V VRM Temperature		
CPU VRM Temperature		
CPU1 Temperature		Displays CPU & Ambient System Temperatures.
CPU2 Temperature		
System Temperature		
CPU1 Fan Speed		Displays speed of fans connected to appropriate Fan headers.
CPU2 Fan Speed		
FAN1 Speed		
FAN2 Speed		
FAN3 Speed		
FAN4 Speed		

FAN5 Speed		
------------	--	--

Feature	Option	Description
Hardware Health Event Monitoring		
Mainboard Voltages Report		Displays Voltage for CPU, memory, & other devices.
Auto FAN 1, 2, 3 Speed Control	Disabled	FAN power duty cycle is auto dynamic programmed in selected temperature range or be set at a fixed percentage.
	Enabled	
Chassis Intrusion Detect	Disabled	Enabled / Disabled: when chassis open event is detected, BIOS will record the event.
	Enabled	

3.04.4.1 – Mainboard Voltages Report Sub-Menu

BIOS Setup Utility	
Main	Advanced PCI/PnP Boot Security Chipset Power Exit
Board Voltages Event Monitoring	
CPU1 Vcore	: x.xxx V
CPU2 Vcore	: x.xxx V
+3.3 Vin	: x.xxx V
CPU2 DIMM Vref	: x.xxx V
CPU2 DIMM Voltage	: x.xxx V
CPU1-CPU2 Vhtlink	: x.xxx V
CPU2 DIMM Vref	: x.xxx V
CPU2 DIMM Voltage	: x.xxx V
+5 Vin	: x.xxx V
+3.3VSB	: x.xxx V
+12 Vin	: xx.xxx V
	Use [ENTER], [TAB] or [SHIFT_TAB] to select a field
	Use [+] or [-] to configure system time.
	? ? Select Screen
	?? Select Item
	+/- Change Option
	Tab Select Field
	F1 General Help
	F10 Save and Exit
	ESC Exit

3.04.5 –ACPI Configuration Sub-Menu

Use this screen to select options for ACPI. Use the up and down arrow (↑/↓) keys to select an item. Use the Plus and Minus (+/-) keys to change the value of the selected option. A description of the selected item appears on the right side of the screen. The settings are described on this page. The screen is shown below.

BIOS Setup Utility	
Main	Advanced PCI/PnP Boot Security Chipset Power Exit
ACPI Configuration	
ACPI Aware O/S	[Yes]
▶ Advanced ACPI Configuration	Use [ENTER], [TAB] or [SHIFT_TAB] to select a field Use [+] or [-] to configure system time. ?? Select Screen ?? Select Item +/- Change Option F1 General Help F10 Save and Exit ESC Exit

Feature	Option	Description
ACPI Configuration		
ACPI Aware O/S	Yes	Yes allows the system to utilize ACPI (Advanced Configuration and Power Interface) specification.
	No	

3.04.5.1 – Advanced ACPI Configuration Sub-Menu

Use this screen to select options for the ACPI Advanced Configuration Settings. Use the up and down arrow (↑/↓) keys to select an item. Use the Plus and Minus (+/-) keys to change the value of the selected option. A description of the selected item appears on the right side of the screen. The settings are described on this page. The screen is shown below.

BIOS Setup Utility		
Main	Advanced	PCI/PnP Boot Security Chipset Power Exit
Advanced ACPI Configuration		Use [ENTER], [TAB] or [SHIFT_TAB] to select a field
ACPI 2.0 Support	[No]	Use [+] or [-] to configure system time. ?? Select Screen ?? Select Item +/- Change Option F1 General Help F10 Save and Exit ESC Exit
ACPI APIC Support	[Enabled]	
Multimedia Timer	[Enabled]	
BIOS → AML ACPI table	[Enabled]	
Headless mode	[Disabled]	

Feature	Option	Description
Advanced ACPI Configuration		
ACPI 2.0 Support	Yes	Set this value to allow or prevent the system to be compliant with the ACPI 2.0 specification.
	No	
ACPI APIC Support	Enabled	This option allows you to define whether or not to enable ACPI management features.
	Disabled	
Multimedia Timer	Enabled	To enable/disable HPET timer.
	Disabled	
BIOS → AML ACPI table	Enabled	Set this value to allow the ACPI BIOS to add a pointer to an OEMB table in the Root System Description Table (RSDT) table. Note: OEMB table is used to pass POST data to the AML code during ACPI O/S operations.
	Disabled	

Headless mode	Enabled	
	Disabled	

3.04.6 – Event Logging details Sub-Menu

You can use this screen to view the Event Log Control Menu. This logs system events (such as CMOS clear, ECC memory errors, etc) and writes the log into NVRAM. Use the up and down arrow (↑/↓) keys to select an item. Use the Plus and Minus (+/-) keys to change the value of the selected option. The settings are described on the following pages.

BIOS Setup Utility	
Main	Advanced
PCI/PnP	Boot Security Chipset Power Exit
Event Logging details	
View Event Log Mark All Events as Read Clear Event Log Event Log Statistics	Use [ENTER], [TAB] or [SHIFT_TAB] to select a field Use [+] or [-] to configure system time. ?? Select Screen ?? Select Item +/- Change Option Enter Go to Sub Screen F1 General Help F10 Save and Exit ESC Exit

Feature	Option	Description
Event Logging details		
View Event Log		View all unread events on the Event Log.
Mark All Events as Read		Marks all events as read.
Clear Event Log		Erase all of events.
Event Log Statistics		Displays the storage capacity & usage of the Event Log.

3.04.7 – Hyper Transport Configuration Sub-Menu

You can use this screen to view the Hyper Transport Configuration Menu. Use the Plus and Minus (+/-) keys to change the value of the selected option. The settings are described on the following pages.

BIOS Setup Utility	
Main	Advanced PCI/PnP Boot Security Chipset Power Exit
Hyper Transport Configuration	Use [ENTER], [TAB] or [SHIFT_TAB] to select a field
CPU1: CPU2 HT Link Speed [Auto]	Use [+] or [-] to configure system time. ?? Select Screen ?? Select Item +/- Change Option F1 General Help F10 Save and Exit ESC Exit
CPU1: CPU2 HT Link Width [Auto]	
CPU1: PCI-X0 HT Link Speed [Auto]	
CPU1: PCI-X0 HT Link Width [Auto]	

Feature	Option	Description
Hyper Transport Configuration		
CPU1: CPU2 HT Link Speed	Auto	Specify CPU1 to CPU2 Hyper Transport Link Clock frequency. If CPU2 is absent, the selection item will be hide.
	200MHz	
	400MHz	
	600MHz	
	800MHz	
CPU1: CPU2 HT Link Width	Auto	Specify CPU1 to CPU2 Hyper Transport Link Data width. If CPU2 is absent, the selection item will be hide.
	2 Bit	
	4 Bit	
	8 Bit	
CPU1: PCI-X0 HT Link Speed	Auto	Specify CPU1 to PCI X Hyper Transport Link Clock frequency.
	200MHz	
	400MHz	
	600MHz	

CPU1: PCI-X0 HT Link Width	Auto	Specify CPU1 to PCI X Hyper Transport Link Data width.
	2 Bit	
	4 Bit	
	8 Bit	
	16 Bit	

3.04.8 Device & PCI Slots Configuration Sub-Menu

You can use this screen to view Device & PCI Slot Configuration Menu. This menu allows the user to enable or disable integrated devices, option ROM, and PCI cards added. Use the up and down arrow (↑/↓) keys to select an item. Use the Plus and Minus (+/-) keys to change the value of the selected option. The settings are described on the following pages.

BIOS Setup Utility		
Main	Advanced	PCI/PnP Boot Security Chipset Power Exit
Onboard Device & PCI Slots Configuration		Use [ENTER], [TAB] or [SHIFT_TAB] to select a field
USB Host Controllers	[Enabled]	Use [+] or [-] to configure system time.
Onboard ATI Video	[Enabled]	
Onboard Serial ATA	[Enabled]	
Onboard Gigabit LAN	[Enabled]	
Gigabit LAN Option Rom	[Disabled]	
Onboard 100/10Mbit LAN	[Enabled]	
100/10Mbit LAN Option Rom	[Disabled]	?? Select Screen
PCI1 Slot (64bit)	[Enabled]	?? Select Item
PCI2 Slot (64bit)	[Enabled]	+/- Change Option
PCI3 Slot (32bit)	[Enabled]	F1 General Help
PCI4 Slot (32bit)	[Enabled]	F10 Save and Exit
		ESC Exit

Feature	Option	Description
Onboard Device & PCI Slots Configuration		
USB Host Controllers	Enabled	
	Disabled	
Onboard ATI, Serial ATA, 100/10Mbit & Gigabit Ethernet	Enabled	Allows user to enable or disable onboard ATI video, Serial ATA controller and Onboard Gigabit LAN individually.
	Disabled	
	N/A	
Gigabit LAN Option Rom	Enabled	Allows user to enable or disable onboard Gigabit LAN controller option ROM (BIOS).
	Disabled	
100/10Mbit LAN Option Rom	Enabled	Allows user to enable or disable onboard 100/10Mbit LAN controller option ROM (BIOS).
	Disabled	

PCI1 Slot (64bit)	Enabled	Allows user to enable or disable device in PCI slot 1.
	Disabled	
PCI2 Slot (64bit)	Enabled	Allows user to enable or disable device in PCI slot 2.
	Disabled	
PCI3 Slot (32bit)	Enabled	Allows user to enable or disable device in PCI slot 3.
	Disabled	
PCI4 Slot (32bit)	Enabled	Allows user to enable or disable device in PCI slot 4.
	Disabled	

3.04.9 – Remote Access Configuration Sub-Menu

You can use this screen to view the Remote Access Configuration Menu. This feature allows access to the Server remotely via serial port. Use the up and down arrow (↑/↓) keys to select an item. Use the Plus and Minus (+/-) keys to change the value of the selected option. The settings are described on the following pages.

BIOS Setup Utility	
Main	Advanced
PCI/PnP	Boot Security Chipset Power Exit
Configure Remote Access type and parameters	
Remote Access	[Disabled]
Use [ENTER], [TAB] or [SHIFT_TAB] to select a field Use [+] or [-] to configure system time. ?? Select Screen ?? Select Item +/- Change Field F1 General Help F10 Save and Exit ESC Exit	

Feature	Option	Description
Configure Remote Access type and parameters		
Remote Access	Disabled	Enables remote access to system through serial port.
	Serial	

3.04.10 – USB Configuration Sub-Menu

You can use this screen to view the USB Configuration Menu. Use the up and down arrow (↑/↓) keys to select an item. Use the Plus and Minus (+/-) keys to change the value of the selected option. The settings are described on the following pages.

BIOS Setup Utility	
Main	Advanced
PCI/PnP	Boot
Security	Chipset
Power	Exit
USB Configuration	
Module Version – X.XX.X-X.X	Use [ENTER], [TAB] or [SHIFT_TAB] to select a field
USB Devices Enabled: None	Use [+] or [-] to configure system time.
Legacy USB Support [Enabled]	?? Select Screen
USB Keyboard Legacy Support [Enabled]	?? Select Item
USB Mouse Legacy Support [Enabled]	+/- Change Option
USB Storage Device Support [Enabled]	F1 General Help
	F10 Save and Exit
	ESC Exit

Feature	Option	Description
USB Configuration		

Legacy USB Support	Auto	Enables support for legacy USB devices such as keyboards, mice, & bootable USB devices.
	Disabled	
	Enabled	
USB Keyboard Legacy Support	Disabled	Select "Enabled" if your system contains a USB controller and you have a USB Keyboard.
	Enabled	
USB Mouse Legacy Support	Disabled	Select "Enabled" if your system contains a USB controller and you have a USB mouse.
	Enabled	
USB Storage Device Support	Disabled	Select "Enabled" if your system contains a USB controller and you have a USB Storage Device.
	Enabled	

3.05 –Advanced PCI/PnP Menu

You can use this screen to view PnP (Plug & Play) BIOS Configuration Menu. This menu allows the user to configure how the BIOS assigns resources & resolves conflicts. Use the up and down arrow (↑/↓) keys to select an item. Use the Plus and Minus (+/-) keys to change the value of the selected option. The settings are described on the following pages.

BIOS Setup Utility							
Main	Advanced	PCI/PnP	Boot	Security	Chipset	Power	Exit
Advanced PCI/PnP Settings					Use [ENTER], [TAB] or		

<p>WARNING: Setting wrong values in below sections may cause system to malfunction.</p>		<p>[SHIFT_TAB] to select a field</p>
<p>Plug & Play OS</p>	<p>[Yes]</p>	<p>Use [+] or [-] to configure system time.</p>
<p>PCI Latency Timer</p>	<p>[64]</p>	
<p>PCI BUS SCAN Order</p>	<p>[Descent]</p>	
<p>Allocate IRQ to PCI VGA</p>	<p>[Yes]</p>	
<p>Palette Snooping</p>	<p>[Disabled]</p>	
<p>PCI IDE BusMaster</p>	<p>[Disabled]</p>	
<p>IRQ3</p>	<p>[Available]</p>	
<p>IRQ4</p>	<p>[Available]</p>	
<p>IRQ5</p>	<p>[Available]</p>	
<p>IRQ7</p>	<p>[Available]</p>	
<p>IRQ9</p>	<p>[Available]</p>	
<p>IRQ10</p>	<p>[Available]</p>	
<p>IRQ11</p>	<p>[Available]</p>	
<p>IRQ14</p>	<p>[Available]</p>	
<p>IRQ15</p>	<p>[Available]</p>	
<p>DMA Channel_0</p>	<p>[Available]</p>	<p>? ? Select Screen</p>
<p>DMA Channel_1</p>	<p>[Available]</p>	
<p>DMA Channel_3</p>	<p>[Available]</p>	<p>?? Select Item</p>
<p>DMA Channel_5</p>	<p>[Available]</p>	<p>+/- Change Option</p>
<p>DMA Channel_6</p>	<p>[Available]</p>	<p>F1 General Help</p>
<p>DMA Channel_7</p>	<p>[Available]</p>	<p>F10 Save and Exit ESC Exit</p>

Feature	Option	Description
Advanced PCI/PnP Settings		
Plug & Play OS	Yes	The Yes setting allows the operating system to change the interrupt, I/O, and DMA settings. Set this option if the system is running Plug and Play aware operating systems.
	No	Set No for operating systems that do not meet the Plug and Play specifications. It allows the BIOS to configure all the devices in the system.
PCI Latency Timer	32	This setting controls how many PCI clocks each PCI device can hold the bus before another PCI device takes over. When set to higher values, every PCI device can conduct transactions for a longer time and thus improve the effective PCI bandwidth.
	64	
	96	
	128	
	160	
	192	
	248	
PCI BUS SCAN Order	Ascent	Ascent: Scan PCI bus from bus 0 to maximum.
	Descent	Descent: Scan PCI bus from maximum to bus 0.
Allocate IRQ to PCI VGA	Yes	Allows or restricts the system from giving the VGA adapter an IRQ.
	No	
Palette Snooping	Disabled	This is the default setting and should not be changed unless the VGA card manufacturer requires Palette Snooping to be Enabled.
	Enabled	
PCI IDE Bus Master	Disabled	ENABLED: BIOS uses PCI bus mastering for reading / writing to IDE drives.
	Enabled	
IRQ3 ~ IRQ15	Available	Allows user to reserve a specific IRQ for a legacy device (Note: most hardware devices & OS used do not support manual assigned).
	Reserved	
DMA0 ~ 7	Available	Allows user to reserve a specific DMA for a legacy device.
	Reserved	

3.06 – BIOS Boot Settings Menu

You can display Boot Setup option by highlighting it using the Arrow (↑/↓) keys and pressing Enter. The settings are described on the following pages.

BIOS Setup Utility							
Main	Advanced	PCI/PnP	Boot	Security	Chipset	Power	Exit
Boot Settings				Use [ENTER], [TAB] or [SHIFT_TAB] to select a field			
▶ Boot Settings Configuration				Use [+] or [-] to configure system time.			
▶ Boot Device Priority				?? Select Screen			
▶ Hard Disk Drives				?? Select Item			
▶ Removable Drives				Enter Go to Sub Screen			
▶ ATAPI CDROM Drives				F1 General Help			
				F10 Save and Exit			
				ESC Exit			

3.06.1 – Boot Settings Configuration Sub-Menu

Use this screen to select options for the Boot Settings Configuration. Use the up and down arrow (↑/↓) keys to select an item. Use the Plus and Minus (+/-) keys to change the value of the selected option.

BIOS Setup Utility							
Main	Advanced	PCI/PnP	Boot	Security	Chipset	Power	Exit
Boot Settings Configuration				Use [ENTER], [TAB] or [SHIFT_TAB] to select a field			
Quick Boot				[Disabled]			
Quiet Boot				[Disabled]			
Add On ROM Display Mode				[Force BIOS]			
Boot up Number-Lock				[On]			
PS/2 Mouse Support				[Enabled]			
Typematic Rate				[Fast]			
Keyboard Error Report				[Disabled]			
Boot To OS/2				[No]			
Wait for 'F1' If Error				[Enabled]			
Hit 'DEL' Message Display				[Enabled]			
Interrupt 19 Capture				[Disabled]			
				Use [+] or [-] to configure system time.			
				?? Select Screen			
				?? Select Item			
				+/- Change Option			
				F1 General Help			
				F10 Save and Exit			
				ESC Exit			

Feature	Option	Description
Boot Settings Configuration		
Quick Boot Mode	Enabled	This option allows user bypass BIOS self test during POST.
	Disabled	
Quiet Boot	Disabled	Enable this option to hide BIOS Post messages during POST.
	Enabled	
Add On ROM Display Mode	Force BIOS	Allows user to force BIOS/Option ROM of add on cards to be displayed during quiet boot.
	Keep Current	
Boot up Number-Lock	On	Choose status of keyboard NUM LOCK key.
	Off	
PS/2 Mouse Support	Enabled	Allows user to choose status of PS/2 mouse support.
	Disabled	
Typematic Rate	Fast	Choose the speed at which keys are repeated.
	Slow	
Keyboard Error Report	Disabled	Enable / Disable Keyboards error report.
	Enabled	
Boot To OS/2	No	Set this option to yes only if booting to OS/2.
	Yes	
Wait for 'F1' If Error	Enabled	Allows user to disable the "Press F1 to Continue" error message when error is detected.
	Disabled	
Hit 'DEL' Message Display	Enabled	Allows user to disable the "Press DEL to enter setup" message during POST.
	Disabled	
Interrupt 19 Capture	Disabled	Allows devices (such as network card) to capture INT19 for booting.
	Enabled	

3.06.2 – Boot Device Priority Sub-Menu

Use this screen to select options for the Boot Device Priority. Use the up and down arrow (↑/↓) keys to select an item. Use the Plus and Minus (+/-) keys to change the value of the selected option.

BIOS Setup Utility	
Main	Advanced PCI/PnP Boot Security Chipset Power Exit
Boot Device Priority	
1st Boot Device	[1st FLOPPY DRIVE]
Use [ENTER], [TAB] or [SHIFT_TAB] to select a field Use [+] or [-] to configure system time. ?? Select Screen ?? Select Item +/- Change Option F1 General Help F10 Save and Exit ESC Exit	

Feature	Option	Description
Boot Device Priority		
1st Boot Device	1st FLOPPY DRIVE	Settings for boot priority. These can be customized depending on your preference.
	Disabled	

3.06.3 – Hard Disk Drives Sub-Menu

Use this screen to select options for the Hard Disk Drives. Use the up and down arrow (↑/↓) keys to select an item. Use the Plus and Minus (+/-) keys to change the value of the selected option.

BIOS Setup Utility	
Main	Advanced PCI/PnP Boot Security Chipset Power Exit
Hard Disk Drives	
1st Drive	[xx,xxx-xxxxx:xxx]
Use [ENTER], [TAB] or [SHIFT_TAB] to select a field Use [+] or [-] to configure system time. ?? Select Screen ?? Select Item +/- Change Option F1 General Help F10 Save and Exit ESC Exit	

Feature	Option	Description
Hard Disk Drives		
1st Drive	xx,xxx-xxxxx:xxx	
	Disabled	

3.06.4 – Removable Drives Sub-Menu

Use this screen to select options for the Removable Drives. Use the up and down arrow (↑/↓) keys to select an item. Use the Plus and Minus (+/-) keys to change the value of the selected option.

BIOS Setup Utility	
Main	Advanced PCI/PnP Boot Security Chipset Power Exit
Removable Drives	
1st Device	[1st FLOPPY DRIVE]
Use [ENTER], [TAB] or [SHIFT_TAB] to select a field Use [+] or [-] to configure system time. ?? Select Screen ?? Select Item +/- Change Option F1 General Help F10 Save and Exit ESC Exit	

Feature	Option	Description
Removable Drives		
1st Device	1st FLOPPY DRIVE	Specifies the boot sequence for removable drive booting. This option will show all removable devices.
	Disabled	

3.06.5 – ATAPI CDROM Drives Sub-Menu

Use this screen to select options for the ATAPI CDROM Drives. Use the up and down arrow (↑/↓) keys to select an item. Use the Plus and Minus (+/-) keys to change the value of the selected option.

BIOS Setup Utility	
Main	Advanced PCI/PnP Boot Security Chipset Power Exit
ATAPI CDROM Drives	
1st Drive	[xx,xxx-xxxxx:xxx]
Use [ENTER], [TAB] or [SHIFT_TAB] to select a field Use [+] or [-] to configure system time. ?? Select Screen ?? Select Item +/- Change Option F1 General Help F10 Save and Exit ESC Exit	

Feature	Option	Description
ATAPI CDROM Drives		
1st Drive	xx,xxx-xxxxx:xxx	
	Disabled	

3.07 – BIOS Security Menu

The system can be configured so that all users must enter a password every time the system boots or when BIOS Setup is entered, using either the Supervisor password or User password. The Supervisor and User passwords activate two different levels of password security. If you select password support, you are prompted for a one to six character password. Type the password on the keyboard. The password does not appear on the screen when typed. Make sure you write it down. If you forget it, you must clear CMOS and reconfigure.

BIOS Setup Utility							
Main	Advanced	PCI/PnP	Boot	Security	Chipset	Power	Exit
Security Settings					Use [ENTER], [TAB] or [SHIFT_TAB] to select a field		
Supervisor Password: User Password:					Use [+] or [-] to configure system time.		
Change Supervisor Password Change User Password Clear User Password					?? Select Screen		
Boot Sector Virus Protection [Disabled]					?? Select Item +/- Change Option F1 General Help F10 Save and Exit ESC Exit		

Feature	Option	Description
Security Settings		
Supervisor Password:	Not Installed	If the password has been set, Installed displays. If no password is set, Not Installed displays.
	Installed	
User Password:	Not Installed	If the password has been set, Installed displays. If no password is set, Not Installed displays.
	Installed	
Change Supervisor Password		Select this option to change Supervisor Password.
Change User Password		Select this option to change User Password.
Clear User Password		Select this option to clear User Password.
Boot Sector Virus Protection	Disabled	Protects the first sector of the Hard Drive from being written.
	Enabled	

3.08 – BIOS Chipset Settings Menu

This menu allows the user to customize functions of the AMD Chipsets. North Bridge configuration contains options for Memory & CPU settings. South Bridge configuration contains options for SM Bus & USB. Additional configuration for the AMD8131 PCI-X Tunnel is available in the PCI-X Configuration Menu. Select a menu by highlighting it using the Arrow (↑/↓) keys and pressing Enter. The settings are described on the following pages.

BIOS Setup Utility							
Main	Advanced	PCI/PnP	Boot	Security	Chipset	Power	Exit
Chipset Settings					Use [ENTER], [TAB] or [SHIFT_TAB] to select a field		
<ul style="list-style-type: none"> ▶ North Bridge Configuration ▶ South Bridge Configuration ▶ PCI-X Configuration 					Use [+] or [-] to configure system time.		
Clock Gen. Spread Spectrum					[Disabled]		
					?? Select Screen ?? Select Item +/- Change Option Enter Go to Sub Screen F1 General Help F10 Save and Exit ESC Exit		

Feature	Option	Description
Chipset Settings		
Clock Gen. Spread Spectrum	Disabled	Enabled/Disabled clock generator spread spectrum feature
	Enabled	

3.08.1 – North Bridge Chipset Configuration Sub-Menu

This menu gives options for customizing memory & Hypertransport settings. Select a menu by highlighting it using the Arrow (↑/↓) keys and pressing Enter. The settings are described on the following pages.

BIOS Setup Utility							
Main	Advanced	PCI/PnP	Boot	Security	Chipset	Power	Exit
North Bridge Chipset Configuration					Use [ENTER], [TAB] or [SHIFT_TAB] to select a field		
<ul style="list-style-type: none"> ▶ Memory Configuration ▶ ECC Configuration 					Use [+] or [-] to configure system time.		
					?? Select Screen		
					?? Select Item		
					Enter Go to Sub Screen		
					F1 General Help		
					F10 Save and Exit		
					ESC Exit		

3.08.1.1 – Memory Configuration Sub-Menu

This menu has options for memory speed & latency. Use the up and down arrow (↑/↓) keys to select an item. Use the Plus and Minus (+/-) keys to change the value of the selected option.

BIOS Setup Utility							
Main	Advanced	PCI/PnP	Boot	Security	Chipset	Power	Exit
Memory Configuration					Use [ENTER], [TAB] or [SHIFT_TAB] to select a field		
Bank Interleaving					[Auto]		
Node Interleaving					[Disabled]		
Burst Length					[8 Beats]		
					Use [+] or [-] to configure system time.		
					?? Select Screen		
					?? Select Item		
					+/- Change Option		
					F1 General Help		
					F10 Save and Exit		
					ESC Exit		

Feature	Option	Description
Memory Configuration		
Bank Interleaving	Disabled	Allows memory access to be spread across memory banks.
	Auto	
Node Interleaving	Disabled	Allows memory access to be spread across memory nodes.
	Auto	
Burst Length	8beats	Burst length must be set to 8beats for 128bit memory support.
	4beats	

3.08.1.2 –ECC Configuration Sub-Menu

This menu allows the user to configure ECC setup for system & DRAM. Use the up and down arrow (↑/↓) keys to select an item. Use the Plus and Minus (+/-) keys to change the value of the selected option.

BIOS Setup Utility	
Main	Advanced PCI/PnP Boot Security Chipset Power Exit
ECC Configuration	
Master ECC Enable	[Enabled]
DRAM ECC Enable	[Enabled]
DRAM BG Scrub	[Disabled]
DRAM SCRUB REDIRECT	[Disabled]
ECC Chip Kill	[Disabled]
L2 Cache BG Scrub	[Disabled]
Data Cache BG Scrub	[Disabled]
Use [ENTER], [TAB] or [SHIFT_TAB] to select a field Use [+] or [-] to configure system time. ?? Select Screen ?? Select Item +/- Change Option F1 General Help F10 Save and Exit ESC Exit	

Feature	Option	Description
ECC Configuration		
Master ECC	Enabled	Enables support on all nodes for ECC error checking and correction.
	Disabled	
DRAM ECC	Disabled	Enables support on all banks for ECC error checking and correction.
	Enabled	
DRAM BG Scrub	Disabled	
	40ns	
	80ns	
	160ns	
	320ns	
	640ns	

	1.28us	
--	--------	--

Feature	Option	Description
DRAM BG Scrub	2.56us	
	5.12us	
	10.2us	
	20.5us	
	41.0us	
	81.9us	
	163.8us	
	327.7us	
DRAM SCRUB REDIRECT	Disabled	
	Enabled	
ECC Chip Kill	Disabled	
	Enabled	
L2 Cache BG Scrub	Disabled	
	40ns	
	80ns	
	160ns	
	320ns	
	640ns	
	1.28us	
	2.56us	
	5.12us	
	10.2us	
	20.5us	
	41.0us	
	81.9us	
	163.8us	
327.7us		
Data Cache BG Scrub	Disabled	
	40ns	
	80ns	
	160ns	
	320ns	
	640ns	
	1.28us	
	2.56us	
	5.12us	
	10.2us	
	20.5us	
	41.0us	
	81.9us	
	163.8us	
327.7us		

3.08.2 – South Bridge Chipset Configuration Sub-Menu

This menu allows the user to enable SM Bus 2.0 controller. Use the up and down arrow (↑/↓) keys to select an item. Use the Plus and Minus (+/-) keys to change the value of the selected option.

BIOS Setup Utility						
Main	Advanced	PCI/PnP	Boot Security	Chipset	Power	Exit
South Bridge Chipset Configuration				Use [ENTER], [TAB] or [SHIFT_TAB] to select a field		
2.0 SM Bus Controller			[Enabled]			
HT Link 0 P-Comp Mode			[Auto]			
HT Link 0 N-Comp Mode			[Auto]			
HT Link 0 RZ-Comp Mode			[Auto]			
				?? Select Screen		
				?? Select Item		
				+/- Change Option		
				F1 General Help		
				F10 Save and Exit		
				ESC Exit		

Feature	Option	Description
South Bridge Chipset Configuration		
2.0 SM Bus Controller	Enabled	Enables/disables the SM Bus 2.0 controller in the AMD8111 I/O Hub
	Disabled	
HT Link 0 P-Comp Mode	Auto	Auto uses hardware compensation values. Other values add to or subtract from hardware generated value. Recommended setting is Auto .
	Data	
	CalComp +Data	
	CalComp -Data	
HT Link 0 N-Comp Mode	Auto	Auto uses hardware compensation values. Other values add to or subtract from hardware generated value. Recommended setting is Auto .
	Data	
	CalComp +Data	
	CalComp -Data	
HT Link 0 RZ-Comp Mode	Auto	Auto uses hardware compensation values. Other values add to or subtract from hardware generated value. Recommended setting is Auto .
	Data	
	CalComp +Data	
	CalComp -Data	

3.08.3 – PCI-X Chipset Configuration Sub-Menu

This menu allows the user to configure HyperTransport data compensation. Changing these options can result in major performance loss & is not recommended. Use the up and down arrow (↑/↓) keys to select an item. Use the Plus and Minus (+/-) keys to change the value of the selected option.

BIOS Setup Utility	
Main	Advanced
PCI/PnP	Boot
Security	Chipset
	Power
	Exit
PCI-X Chipset Configuration	Use [ENTER], [TAB] or [SHIFT_TAB] to select a field
HT Link 0 P-Comp Mode [Auto]	Use [+] or [-] to configure system time. ?? Select Screen ?? Select Item +/- Change Option F1 General Help F10 Save and Exit ESC Exit
HT Link 0 N-Comp Mode [Auto]	
HT Link 0 RZ-Comp Mode [Auto]	
HT Link 1 P-Comp Mode [Auto]	
HT Link 1 N-Comp Mode [Auto]	
HT Link 1 RZ-Comp Mode [Auto]	

Feature	Option	Description
PCI-X Chipset Configuration		
HT Link 0 P-Comp Mode	Auto	Auto uses hardware compensation values. Other values add to or subtract from hardware generated value. Recommended setting is Auto.
	Data	
	CalComp +Data	
	CalComp -Data	
HT Link 0 N-Comp Mode	Auto	Auto uses hardware compensation values. Other values add to or subtract from hardware generated value. Recommended setting is Auto.
	Data	
	CalComp +Data	
	CalComp Data	
HT Link 0 RZ-Comp Mode	Auto	Auto uses hardware compensation values. Other values add to or subtract from hardware generated value. Recommended setting is Auto
	Data	
	CalComp +Data	
	CalComp -Data	
HT Link 1 P-Comp Mode	Auto	Auto uses hardware compensation values. Other values add to or subtract from hardware generated value. Recommended setting is Auto.
	Data	
	CalComp +Data	
	CalComp -Data	
HT Link 1 N-Comp Mode	Auto	Auto uses hardware compensation values. Other values add to or subtract from hardware generated value. Recommended setting is Auto.
	Data	
	CalComp +Data	
	CalComp -Data	
HT Link 0 RZ-Comp Mode	Auto	Auto uses hardware compensation values. Other values add to or
	Data	

	CalComp +Data	subtract from hardware generated value. Recommended setting is Auto.
	CalComp -Data	

3.09 – BIOS Power Menu

Use this screen to select options for power management. Use the up and down arrow (↑/↓) keys to select an item. Use the Plus and Minus (+/-) keys to change the value of the selected option. A description of the selected item appears on the right side of the screen. The settings are described on this page. The screen is shown below.

BIOS Setup Utility							
Main	Advanced	PCI/PnP	Boot	Security	Chipset	Power	Exit
APM Configuration						Use [ENTER], [TAB] or [SHIFT_TAB] to select a field	
Power Management/APM				[Enabled]		Use [+] or [-] to configure system time.	
Resume On Ring				[Disabled]		Use [+] or [-] to configure system time.	
Resume On PME#				[Disabled]		Use [+] or [-] to configure system time.	
Resume On RTC Alarm				[Disabled]		?? Select Screen	
Power Button Mode				[On/Off]		?? Select Item	
Restore AC Power Loss				[Last State]		+/- Change Option F1 General Help F10 Save and Exit ESC Exit	

Feature	Option	Description
APM Configuration		
Power Management/APM	Disabled	Disabled prevents the chipset power management and APM (Advanced Power Management) features.
	Enabled	Enabled allows the chipset power management and APM features
Resume On Ring	Disabled	When set to Enabled, any event occurring to the COM Ring will awaken a system which has powered down.

	Enabled	
Resume On PME#	Disabled	An input signal from PME on the PCI card awakens the system from a soft off state.
	Enabled	
Resume On RTC Alarm	Disabled	When set to Enabled RTC Alarm resume, you could set the date (of month) and timer (hh:mm:ss), any event occurring at will awaken a system which has been powered down.
	Enabled	
Power Button Mode	On / Off	Specifies how the externally mounted power button on the front of the chassis is used.
	Standby	
	Suspend	

Feature	Option	Description
APM Configuration		
Restore on AC/Power Loss	Power On	Configures how the system board responds to a power failure
	Power Off	
	Last State	

3.10 – BIOS Exit Menu

You can display an Exit BIOS Setup option by highlighting it Arrow (↑/↓) keys and pressing Enter.

BIOS Setup Utility							
Main	Advanced	PCI/PnP	Boot	Security	Chipset	Power	Exit
Exit Options					Use [ENTER], [TAB] or [SHIFT_TAB] to select a field		
Save Changes and Exit					Use [+] or [-] to configure system time.		
Discard Changes and Exit							
Discard Charges							
Load Optimal Defaults					?? Select Screen		
Load Failsafe Defaults					?? Select Item		
					Enter Go to Sub Screen		
					F1 General Help		
					F10 Save and Exit		
					ESC Exit		

Save Changes and Exit

Use this option to exit setup utility and re-boot.
All new selections you have made are stored into CMOS.
System will use the new settings to boot up.

Discard Changes and Exit

Use this option to exit setup utility and re-boot.
All new selections you have made are not stored into CMOS.
System will use the old settings to boot up.

Discard Changes

Use this option to restore all new setup values that you have made but not saved into CMOS.

Load Optimal Defaults

Use this option to load default performance setup values.
Use this option when system CMOS values have been corrupted or modified incorrectly.

Load Failsafe Defaults

Use this option to load all default failsafe setup values.
Use this option when troubleshooting

Chapter 4: Diagnostics

Note: if you experience problems with setting up your system, always check the following things in the following order:

CPU, Memory, Video

By checking these items, you will most likely find out what the problem might have been when setting up your system. For more information on troubleshooting, check the Tyan website at: <http://www.tyan.com>.

4.01 Beep Codes

Fatal errors which halt the boot process are communicated through a series of audible beeps.

- (1) Memory module initialization failed
 - (a) memory modules might not be plugged in correct configuration
 - (b) wrong type of memory
 - (c) bad memory modules
- (2) Graphics initialization failed

Before contacting your vendor or Tyan Technical Support, be sure that you note as much as you can about the beep code length and order that you experience. Also, be ready with information regarding add-in cards, drives and O/S to speed the support process and come to a quicker solution.

4.2 Flash Utility

Every BIOS file is unique for the motherboard it was designed for. For Flash Utilities, BIOS downloads, and information on how to properly use the Flash Utility with your motherboard, please check the Tyan web site: <http://www.tyan.com>

NOTE	Please be aware that by flashing your BIOS, you agree that in the event of a BIOS flash failure, you must contact your dealer for a replacement BIOS. There are no exceptions. Tyan does not have a policy for replacing BIOS chips directly with end users. In no event will Tyan be held responsible for damages done by the end user.
-------------	--

Appendix I: Glossary

ACPI (Advanced Configuration and Power Interface): a power management specification that allows the operating system to control the amount of power distributed to the computer's devices. Devices not in use can be turned off, reducing unnecessary power expenditure.

AGP (Accelerated Graphics Port): a PCI-based interface which was designed specifically for demands of 3D graphics applications. The 32-bit AGP channel directly links the graphics controller to the main memory. While the channel runs only at 66 MHz, it supports data transmission during both the rising and falling ends of the clock cycle, yielding an effective speed of 133 MHz.

ATAPI (AT Attachment Packet Interface): also known as IDE or ATA; a drive implementation that includes the disk controller on the device itself. It allows CD-ROMs and tape drives to be configured as master or slave devices, just like HDDs.

ATX: the form factor designed to replace the AT form factor. It improves on the AT design by rotating the board 90 degrees, so that the IDE connectors are closer to the drive bays, and the CPU is closer to the power supply and cooling fan. The keyboard, mouse, USB, serial, and parallel ports are built-in.

Bandwidth: refers to carrying capacity. The greater the bandwidth, the more data the bus, phone line, or other electrical path can carry. Greater bandwidth results in greater speed.

BBS (BIOS Boot Specification): a feature within the BIOS that creates, prioritizes, and maintains a list of all Initial Program Load (IPL) devices, and then stores that list in NVRAM. IPL devices have the ability to load and execute an OS, as well as provide the ability to return to the BIOS if the OS load process fails. At that point, the next IPL device is called upon to attempt loading of the OS.

BIOS (Basic Input/Output System): the program that resides in the ROM chip, which provides the basic instructions for controlling your computer's hardware. Both the operating system and application software use BIOS routines to ensure compatibility.

Buffer: a portion of RAM which is used to temporarily store data; usually from an application though it is also used when printing and in most keyboard drivers. The CPU can manipulate data in a buffer before copying it to a disk drive. While this improves system performance (reading to or writing from a disk drive a single time is much faster than doing so repeatedly) there is the possibility of losing your data should the system crash. Information in a buffer is temporarily stored, not permanently saved.

Bus: a data pathway. The term is used especially to refer to the connection between the processor and system memory, and between the processor and PCI or ISA local buses.

Bus mastering: allows peripheral devices and IDEs to access the system memory without going through the CPU (similar to DMA channels).

Cache: a temporary storage area for data that will be needed often by an application. Using a cache lowers data access times since the information is stored in SRAM instead of slower DRAM. Note that the cache is also much smaller than your regular memory: a typical cache size is 512KB, while you may have as much as 4GB of regular memory.

Closed and open jumpers: jumpers and jumper pins are active when they are "on" or "closed", and inactive when they are "off" or "open".

CMOS (Complementary Metal-Oxide Semiconductors): chips that hold the basic startup information for the BIOS.

COM port: another name for the serial port, which is called as such because it transmits the eight bits of a byte of data along one wire, and receives data on another single wire (that is, the data is transmitted in serial form, one bit after another). Parallel ports transmit the bits of a byte on eight different wires at the same time (that is, in parallel form, eight bits at the same time).

DDR (Double Data Rate): a technology designed to double the clock speed of the memory. It activates output on both the rising and falling edge of the system clock rather than on just the rising edge, potentially doubling output.

DIMM (Dual In-line Memory Module): faster and more capacious form of RAM than SIMMs, and do not need to be installed in pairs.

DIMM bank: sometimes called DIMM socket because the physical slot and the logical unit are the same. That is, one DIMM module fits into one DIMM socket, which is capable of acting as a memory bank.

DMA (Direct Memory Access): channels that are similar to IRQs. DMA channels allow hardware devices (like soundcards or keyboards) to access the main memory without involving the CPU. This frees up CPU resources for other tasks. As with IRQs, it is vital that you do not double up devices on a single line. Plug-n-Play devices will take care of this for you.

DRAM (Dynamic RAM): widely available, very affordable form of RAM which loses data if it is not recharged regularly (every few milliseconds). This refresh requirement makes DRAM three to ten times slower than non-recharged RAM such as SRAM.

ECC (Error Correction Code or Error Checking and Correcting): allows data to be checked for errors during run-time. Errors can subsequently be corrected at the same time that they're found.

EEPROM (Electrically Erasable Programmable ROM): also called Flash BIOS, it is a ROM chip which can, unlike normal ROM, be updated. This allows you to keep up with changes in the BIOS programs without having to buy a new chip. TYAN's BIOS updates can be found at <http://www.tyan.com>

ESCD (Extended System Configuration Data): a format for storing information about Plug-n-Play devices in the system BIOS. This information helps properly configure the system each time it boots.

Firmware: low-level software that controls the system hardware.

Form factor: an industry term for the size, shape, power supply type, and external connector type of the Personal Computer Board (PCB) or motherboard. The standard form factors are the AT and ATX.

Global timer: onboard hardware timer, such as the Real-Time Clock (RTC).

HDD: stands for Hard Disk Drive, a type of fixed drive.

H-SYNC: controls the horizontal synchronization/properties of the monitor.

HyperTransport™: a high speed, low latency, scalable point-to-point link for interconnecting ICs on boards. It can be significantly faster than a PCI bus for an equivalent number of pins. It provides the bandwidth and flexibility critical for today's networking and computing platforms while retaining the fundamental programming model of PCI.

IC (Integrated Circuit): the formal name for the computer chip.

IDE (Integrated Device/Drive Electronics): a simple, self-contained HDD interface. It can handle drives up to 8.4 GB in size. Almost all IDEs sold now are in fact Enhanced IDEs (EIDEs), with maximum capacity determined by the hardware controller.

IDE INT (IDE Interrupt): a hardware interrupt signal that goes to the IDE.

I/O (Input/Output): the connection between your computer and another piece of hardware (mouse, keyboard, etc.)

IRQ (Interrupt Request): an electronic request that runs from a hardware device to the CPU. The interrupt controller assigns priorities to incoming requests and delivers them to the CPU. It is important that there is only one device hooked up to each IRQ line; doubling up devices on IRQ lines can lock up your system. Plug-n-Play operating systems can take care of these details for you.

Latency: the amount of time that one part of a system spends waiting for another part to catch up. This occurs most commonly when the system sends data out to a peripheral device and has to wait for the peripheral to spread (peripherals tend to be slower than onboard system components).

NVRAM: ROM and EEPROM are both examples of Non-Volatile RAM, memory that holds its data without power. DRAM, in contrast, is volatile.

Parallel port: transmits the bits of a byte on eight different wires at the same time.

PCI (Peripheral Component Interconnect): a 32 or 64-bit local bus (data pathway) which is faster than the ISA bus. Local buses are those which operate within a single system (as opposed to a network bus, which connects multiple systems).

PCI PIO (PCI Programmable Input/Output) modes: the data transfer modes used by IDE drives. These modes use the CPU for data transfer (in contrast, DMA channels do not). PCI refers to the type of bus used by these modes to communicate with the CPU.

PCI-to-PCI bridge: allows you to connect multiple PCI devices onto one PCI slot.

Pipeline burst SRAM: a fast secondary cache. It is used as a secondary cache because SRAM is slower than SDRAM, but usually larger. Data is cached first to the faster primary cache, and then, when the primary cache is full, to the slower secondary cache.

PnP (Plug-n-Play): a design standard that has become ascendant in the industry. Plug-n-Play devices require little set-up to use. Devices and operating systems that are not Plug-n-Play require you to reconfigure your system each time you add or change any part of your hardware.

PXE (Preboot Execution Environment): one of four components that together make up the Wired for Management 2.0 baseline specification. PXE was designed to define a standard set of preboot protocol services within a client with the goal of allowing networked-based booting to boot using industry standard protocols.

RAID (Redundant Array of Independent Disks): a way for the same data to be stored in different places on many hard drives. By using this method, the data is stored redundantly and multiple hard drives will appear as a single drive to the operating system. RAID level 0 is known as striping, where data is striped (or overlapped) across multiple hard drives, but offers no fault-tolerance. RAID level 1 is known as mirroring, which stores the data within at least two hard drives, but does not stripe. RAID level 1 also allows for faster access time and fault-tolerance, since either hard drive can be read at the same time. RAID level 0+1 is both striping and mirroring, providing fault-tolerance, striping, and faster access all at the same time.

RAIDIOS: RAID I/O Steering (Intel)

RAM (Random Access Memory): technically refers to a type of memory where any byte can be accessed without touching the adjacent data and is often referred to the system's main memory. This memory is available to any program running on the computer.

ROM (Read-Only Memory): a storage chip which contains the BIOS; the basic instructions required to boot the computer and start up the operating system.

SDRAM (Synchronous Dynamic RAM): called as such because it can keep two sets of memory addresses open simultaneously. By transferring data alternately from one set of addresses and then the other, SDRAM cuts down on the delays associated with non-synchronous RAM, which must close one address bank before opening the next.

Serial port: called as such because it transmits the eight bits of a byte of data along one wire, and receives data on another single wire (that is, the data is transmitted in serial form, one bit after another).

SCSI Interrupt Steering Logic (SISL): Architecture that allows a RAID controller, such as AcceleRAID 150, 200 or 250, to implement RAID on a system board-embedded SCSI bus or a set of SCSI busses. SISL: SCSI Interrupt Steering Logic (LSI) (only on LSI SCSI boards)

Sleep/Suspend mode: in this mode, all devices except the CPU shut down.

SDRAM (Static RAM): unlike DRAM, this type of RAM does not need to be refreshed in order to prevent data loss. Thus, it is faster and more expensive.

Standby mode: in this mode, the video and hard drives shut down; all other devices continue to operate normally.

UltraDMA-33/66/100: a fast version of the old DMA channel. UltraDMA is also called UltraATA. Without a proper UltraDMA controller, your system cannot take advantage of higher data transfer rates of the new UltraDMA/UltraATA hard drives.

USB (Universal Serial Bus): a versatile port. This one port type can function as a serial, parallel, mouse, keyboard or joystick port. It is fast enough to support video transfer, and is capable of supporting up to 127 daisy-chained peripheral devices.

VGA (Video Graphics Array): the PC video display standard

V-SYNC: controls the vertical scanning properties of the monitor.

ZCR (Zero Channel RAID): PCI card that allows a RAID card to use the onboard SCSI chip, thus lowering cost of RAID solution

ZIF Socket (Zero Insertion Force socket): these sockets make it possible to insert CPUs without damaging the sensitive CPU pins. The CPU is lightly placed in an open ZIF socket, and a lever is pulled down. This shifts the processor over and down, guiding it into the board and locking it into place.

Appendix II: SMDC Information Technical Support

Tyan Server Management Daughter Card (SMDC) is a powerful yet cost-efficient solution for high-end server management hardware packages. Tyan's goal is to provide remote system monitoring and control even when the operating system is absent or simply fails. This empowers Tyan's server board with advanced industrial-standard features.

Tyan SMDC is a snap-in card that provides essential server management solution. It enables any IT Manager by providing multi-interfaces to access the hardware remotely and perform **monitor**, **control** and **diagnose** activities effectively.

Tyan SMDC is powered by an intelligent controller known as Baseboard Management Control (BMC). BMC is a standalone mini-CPU and runs on its own Real Time Operating System (RTOS) to complete all different kinds of tasks. Backed by Qlogic's ARM7 technology, IT manager can rest assured his server machines are always taken care.

Tyan SMDC is not a peripheral card. Unlike regular peripheral card such as AGP card, Network card or SCSI card, SMDC does not require any hardware specific driver. As long as a standby power comes into the system, SMDC will begin looking after the system.

Tyan SMDC provides diversified methods to communicate with the hardware. IT manager has the flexibility to choose among *Keyboard Controller Style (KCS)*, *Block Transfer (BT)* style, *Intelligent Chassis Management Bus (ICMB)*, *Intelligent Platform Management Bus (IPMB)*, *Emergency Management Port (EMP)* and standard *IPMI-Over-LAN* communication as defined in latest IPMI 1.5 specification.

Tyan SMDC is compatible with all IPMI-compliance software as well as Tyan System Operator™ (TSO) software package.

By adding SMDC, Tyan's server board becomes a highly manageable and IPMI compatible system with all the advanced features supporting in IPMI Spec.

More detailed information on Tyan's SMDC card can be found on our website:

Technical Support

If a problem arises with your system, you should turn to your dealer for help first. Your system has most likely been configured by them, and they should have the best idea of what hardware and software your system contains. Furthermore, if you purchased your system from a dealer near you, you can bring your system to them to have it serviced instead of attempting to do so yourself (which can have expensive consequences).

Help Resources:

1. See the beep codes section of this manual.
2. See the TYAN website for FAQ's, bulletins, driver updates, and other information: <http://www.tyan.com>
3. Contact your dealer for help BEFORE calling TYAN.
4. Check the TYAN user group: alt.comp.periphs.mainboard.TYAN

Returning Merchandise for Service

During the warranty period, contact your distributor or system vendor FIRST for any product problems. This warranty only covers normal customer use and does not cover damages incurred during shipping or failure due to the alteration, misuse, abuse, or improper maintenance of products.

NOTE: A receipt or copy of your invoice marked with the date of purchase is required before any warranty service can be rendered. You may obtain service by calling the manufacturer for a Return Merchandise Authorization (RMA) number. The RMA number should be prominently displayed on the outside of the shipping carton and the package should be mailed prepaid. TYAN will pay to have the board shipped back to you.



Notice for the USA

Compliance Information Statement (Declaration of Conformity Procedure) DoC
FCC Part 15: This device complies with part 15 of the FCC Rules

Operation is subject to the following conditions:

This device may not cause harmful interference, and
This device must accept any interference received including interference that may cause
undesired operation. If this equipment does cause harmful interference to radio or
television reception, which can be determined by turning the equipment off and on, the
user is encouraged to try one or more of the following measures:

Reorient or relocate the receiving antenna.

Increase the separation between the equipment and the receiver.

Plug the equipment into an outlet on a circuit different from that of the receiver.

Consult the dealer on an experienced radio/television technician for help.

Notice for Canada

This apparatus complies with the Class B limits for radio interference as specified in the
Canadian Department of Communications Radio Interference Regulations. (Cet appareil
est conforme aux norms de Classe B d'interference radio tel que specifie par le Ministere
Canadien des Communications dans les reglements d'ineteference radio.)



Notice for Europe (CE Mark)

This product is in conformity with the Council Directive 89/336/EEC,
92/31/EEC (EMC).

CAUTION: Lithium battery included with this board. Do not puncture, mutilate, or dispose
of battery in fire. Danger of explosion if battery is incorrectly replaced. Replace only with
the same or equivalent type recommended by manufacturer. Dispose of used battery
according to manufacturer instructions and in accordance with your local regulations.

Document #: D1554-100